

DKG-553 MANUAL AND REMOTE START UNIT

DESCRIPTION

The DKG-553 is a comprehensive generator control unit designed to start and stop the generating set both manually and remotely. The manual control is made using the pushbuttons on the front panel. The remote control is made via the **REMOTE START** input signal.

In **AUTOMATIC** position, DKG-553 monitors the **REMOTE START** signal and controls the automatic starting, stopping and load transfer of the generating set. Once the generator is running, it monitors internal protections and external fault inputs. If a fault condition occurs, the unit shuts down the engine automatically and indicates the failure source with the corresponding red led lamp and text.

The operation of the unit is controlled with front panel pushbuttons. The **LOAD TEST**, **TEST**, **AUTO** and **OFF** pushbuttons select the operating mode. Other buttons select the display parameter scroll, alarm mute and lamp test functions.

The DKG-553 provides a comprehensive set of digitally adjustable timers, threshold levels, input and output configurations and operating sequences. The unauthorized access to program parameters is prevented by the program lock input. All programs may be modified via front panel pushbuttons, and do not require an external unit.

The fault conditions are considered in 3 categories as Warnings, Load dumps and Shutdown Alarms. Measured values have separate programmable limits for warning and shutdown conditions. The unit is able to initiate modem calls and sending SMS messages in fault conditions.

Last 100 faults are stored in the event log file. The event log includes not only the date-time information, but also a comprehensive list of measured genset parameters at the time that the fault has occurred.

The service request indicator lamp turns on at the expiration of either engine hours or time limits.

It is possible to monitor and control the operation of the system locally or remotely with the WINDOWS based RAINBOW program.

The unit supports MODBUS protocol enabling communication with PLCs and building management systems. The MODBUS protocol is also supported through GSM and PSTN modems.

The unit is designed for front panel mounting. Connections are made with 2 part plug and socket connectors.

The unit offers triple language support. Default languages are English-Turkish and Chinese.

MEASUREMENTS

Generator Volts: L1-N, L2-N, L3-N
 Generator Volts: L1-L2, L2-L3, L3-L1
 Generator Amps: L1, L2, L3
 Generator KW: L1, L2, L3, total
 Generator pf: L1, L2, L3, total
 Generator Frequency
 Engine rpm
 Battery Voltage
 Engine Coolant Temperature
 Engine Oil Pressure
 Fuel Level

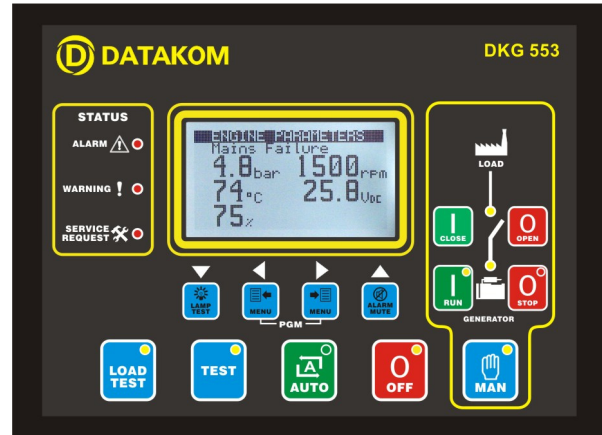

FEATURES

- True RMS measurements**
- Both manual and remote starting and stopping**
- Engine control**
- Gas engine support**
- Engine idle speed control**
- Generator protection**
- Built in alarms and warnings**
- Remote Start operation available**
- Periodic maintenance request indicator**
- Built in daily / weekly / monthly exerciser**
- Event logging with time stamp and measurements**
- Statistical counters**
- Battery backed-up real time clock**
- Weekly operation schedule programs**
- Provision for dual genset operation**
- Load shedding, dummy load**
- Field adjustable parameters**
- RS-232 serial port**
- Software downloadable from serial port**
- Free MS-Windows Remote monitoring SW:**
 - local and modem connection
 - monitoring, download of parameters
 - modem networking
- GSM and PSTN modem support**
- GSM SMS message sending on fault**
- MODBUS communications**
- Blue colour graphic LCD display (128x64 pixels)**
- User friendly graphic indicators**
- Triple language support**
- Customer logo display capability**
- Protected semiconductor digital outputs**
- Magnetic pickup input**
- Configurable analogue inputs: 3**
- Configurable digital inputs: 8**
- Configurable relay outputs: 2**
- Total relay outputs: 5**
- I/O expansion capability**
- Survives cranking dropouts**
- Sealed front panel**
- Plug-in connection system for easy replacement**

STATISTICS

Following incremental counters provide statistics about past performance of the generating set:

Engine Hours Run
Total KW-h
Engine Hours to Service
Time to Service
Number of Engine Cranks
Number of Genset Runs

EVENT LOGGING

The DKG-553 records last 100 events with date-time stamp and a total of 18 measured parameters. Recorded events are:

-shutdown alarms, loaddumps and warnings
-periodic records
-generator status change

WEEKLY OPERATION SCHEDULE

In AUTO mode only, the unit offers the capability of defining a weekly operation schedule. Programmable parameters allow the genset to operate automatically only in defined time limits of each weekday.

The internal battery backed-up real time clock allows precise switching times.

DIGITAL INPUTS

The unit has 8 configurable digital inputs. Each input has following programmable parameters:

-alarm type: shutdown / warning / no alarm
-alarm polling: on engine running / always / on mains OK
-latching / non-latching operation,
-contact type: NO / NC
-switching: BAT+ / BAT-

ANALOG INPUTS

Engine analog inputs are provided for coolant temperature, oil pressure and fuel level. Analog inputs connect to resistive sender units to provide precise and adjustable protection. The inputs have programmable sensor characteristics so that they are suitable for any type and any brand of sensors.

RELAY OUTPUTS

The unit provides 5 relay outputs and 2 of them have programmable functions, selectable from a list. Any function or alarm condition may be output as a relay output.

Using two Relay Expansion Modules, the number of relays may be increased to 21, 16 of them being volt-free contacts.

TELEMETRY AND REMOTE PROGRAMMING

The unit provides the user with large telemetry facilities via its standard RS-232 serial port, connecting either to a PC, PLC or a GSM or PSTN modem. It supports both RAINBOW and MODBUS communication protocols. The standard PC software offers local, Local Area Network (LAN), internet and modem operation capabilities as well as modem networking feature.

The PC program is used for below purposes:

-parameter upload/download
-remote monitoring and control
-diagnostics and analysis

The MODBUS interface allows the unit to be integrated in building management systems.

TECHNICAL SPECIFICATIONS

Alternator voltage: 0 to 300 V-AC (Ph-N)

Alternator frequency: 0-100 Hz.

DC Supply Range: 9.0 to 30.0 V-DC

Cranking dropouts: survives 0 V for 100ms.

Typical Operating Current: 130 mA-DC

DC Outputs: 1A @ 28V

Charge excitation current: min 150mA @ 10 to 30 V-DC

Current inputs: from CTs, .../5A. Max load 0.7VA per phase.

Magnetic pickup input:: 1 – 30 Vac.

Magnetic pickup frequency: 8KHz max.

Analog input range: 0-5000 ohms.

Serial port: RS-232, 2400 bauds, no parity, 1 bit stop

Operating temp.: -20°C (-4°F) to 70 °C (158°F).

Storage temp.: -30°C (-22°F) to 80 °C (176°F).

Maximum humidity: 95% non-condensing.

Dimensions: 202x148 x 48 mm (WxHxD)

Panel Cut-out Dimensions: 183x134 mm minimum.

Weight: 350 g (approx.)

Case Material: High Temperature ABS/PC (UL94-V0)

IP Protection: IP65 from front panel, IP30 from the rear

Conformity (EU directives)

-2006/95/EC (low voltage)

-2004/108/EC (electro-magnetic compatibility)

Norms of reference:

EN 61010 (safety requirements)

EN 61326 (EMC requirements)

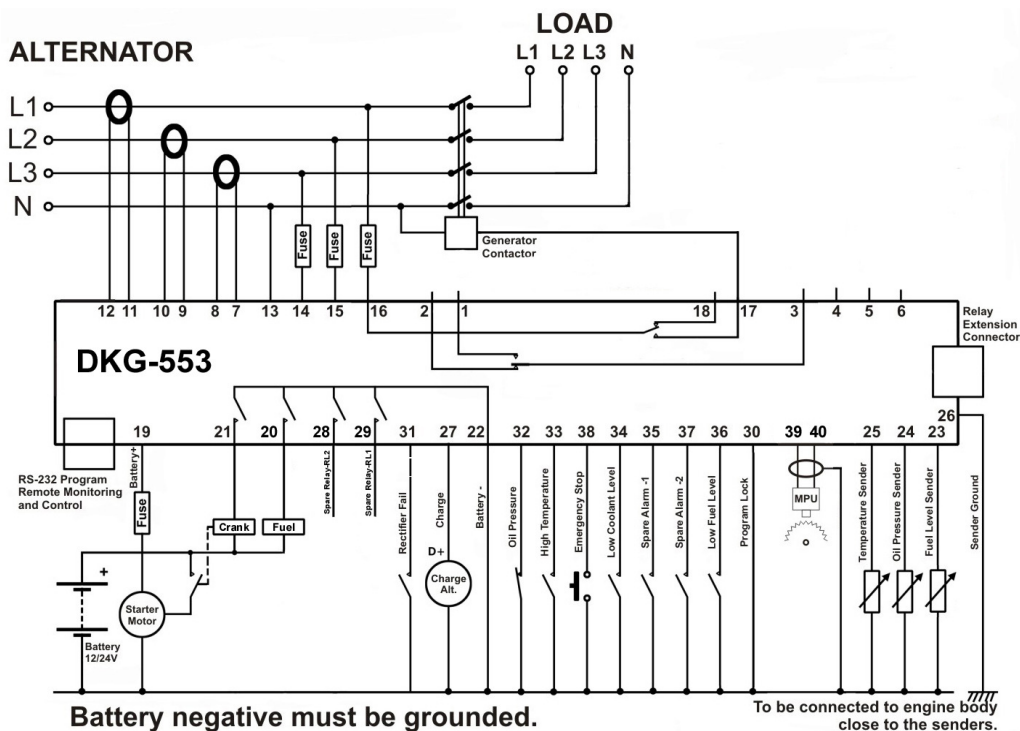

ERROR: stackunderflow
OFFENDING COMMAND: ~

STACK: