

BE72B INSTRUCTION MANUAL V2.0 JAN 2010

BE72B

Bernini Design srl ITALY

The information in this document is subject to change without notice. Bernini Design assumes no responsibility for any errors that may appear in this instruction manual or in the wiring diagram. For more information contact us by fax (0039-0386-31657) or by mail:

bernini@bernini-design.com

BE72B Specifications

DC Supply, Battery Plant	5V up to 36 Vdc
Static Outputs (short circuit proof)	200 mAdc
Key Switch Rating	30 A (30 secs)/80 A (5 secs)
Dimensions-DIN 96 Size	72X72X55 (ex switch /key)
Weight	300 gr
Operating Temperature	-30° C /+70° C
Operating Humidity (non-condensing)	95%

The BE72B includes the basic safeguards to protect an engine. The BE72B features 7 LEDs, 3 Static Outputs and a 30A Key Switch. The BE72B monitors an Oil Pressure-switch, Temperature-switch, Fuel Level-switch, Charger Alternator Voltage and an Emergency-switch. The BE72B provides a MANUAL operating mode, by means of a 30A Key- switch.

WARNING!! High voltage may be present inside the BE72B. To avoid electric-shock hazard, operating personnel must not remove the protective cover. Do not disconnect the grounding connection. The BE72B can start the engine at anytime. Do not work on equipment which is controlled by the BE72B. When servicing the engine, disconnect the battery and battery charger. We recommend that you place warning signs on the equipment indicating the above.

!! W A R N I N G !! Relays and solenoids connected to the BE72B must be suppressed using flywell diodes or suppression devices as indicated in the wiring diagram.

MANUAL MODE instruction:

- A) - Turn the [KEY-switch] clockwise to [PREHEAT] position until the LEDs illuminate.
- B) - Wait until the [OIL PRESSURE] and [CHARGER Failure] LEDs illuminate. If the PREHEAT timer is used, the yellow LED [PREHEAT] will illuminate according to the setting of the potentiometer (back setting: 10-60 secs).
- C) - As soon as the green [ENGINE RUNNING] LED starts blinking, turn the [KEY-switch] clockwise to the spring-loaded momentary position. Turn it until the engine starts. The LED will blink for 15 seconds. If you are not able to start the engine within this period, the FAIL to START alarm will energize.
- D) - To stop the engine, turn the [KEY-switch] fully counter clockwise.

NOTE1

In order to stop the engine, we recommend that you use a FUEL SOLENOID energized to run. If you use a STOP SOLENOID (energized to Stop), turn the potentiometer on the back fully clockwise (see wiring diagram). The BE72 will provide a 60-second stop cycle for output #8. When using the STOP solenoid mode, output #8 will not work as an ALARM output.

Front panel description

[PREHEAT] yellow LED

This indicator illuminates during the Pre-Glow cycle (10 secs to 60 secs via the potentiometer setting on the back of the Be72).

[ENGINE RUNNING] green LED

This LED blinks for 15 seconds, indicating that the BE72B is ready to start the engine (you have to turn the key to start). If the engine does not run within 15 seconds, the 'Starting Failure' alarm will take place. This LED illuminates continuously if the engine runs.

[EMERGENCY] red LED

This LED blinks for 60 seconds, indicating a STOP cycle (if a STOP solenoid mode is used). It illuminates continuously when a shut down has been caused by the Emergency switch (input#3)

[CHARGER FAILURE] red LED

This indicator illuminates when you are going to start the engine, or if a Belt Break shut down occurs.

[OIL PRESSURE] red LED

This indicator illuminates when you are going to start the engine, or if an Oil Pressure shut down occurs.

[FUEL LEVEL] red LED

This indicator blinks when a low fuel condition occurs (a level switch should be connected to terminal #4). This LED illuminates continuously to indicate a shut down, if the switch has been closed for more than 5 minutes.

[TEMPERATURE] red LED

This indicator illuminates when an High Temperature shut down occurs (a temperature-switch should be connected to terminal #2).

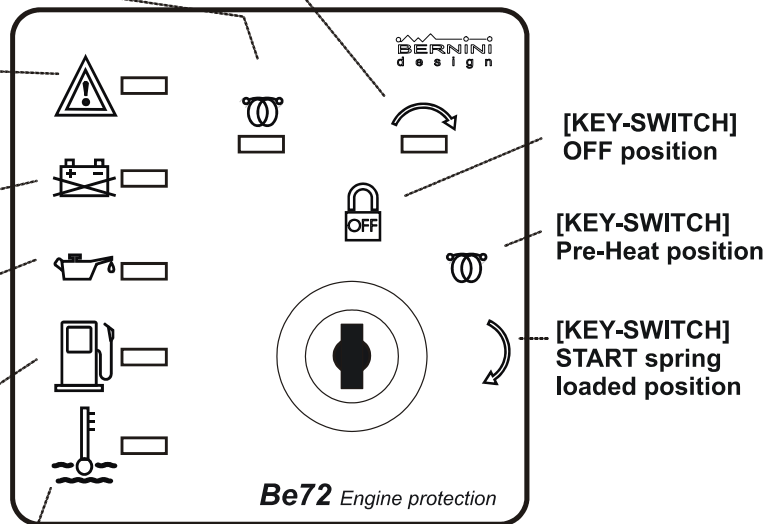

[KEY-SWITCH] OFF position

[KEY-SWITCH] Pre-Heat position

[KEY-SWITCH] START spring loaded position



[STARTING FAILURE ALARM] indication

These LEDs blink alternately (slowly) to indicate a starting failure alarm.

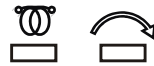

[OVERSPEED] indication

These two LEDs blink alternately (fast) to indicate an OVERSPEED alarm.

Typical Wiring Diagram and dimensions

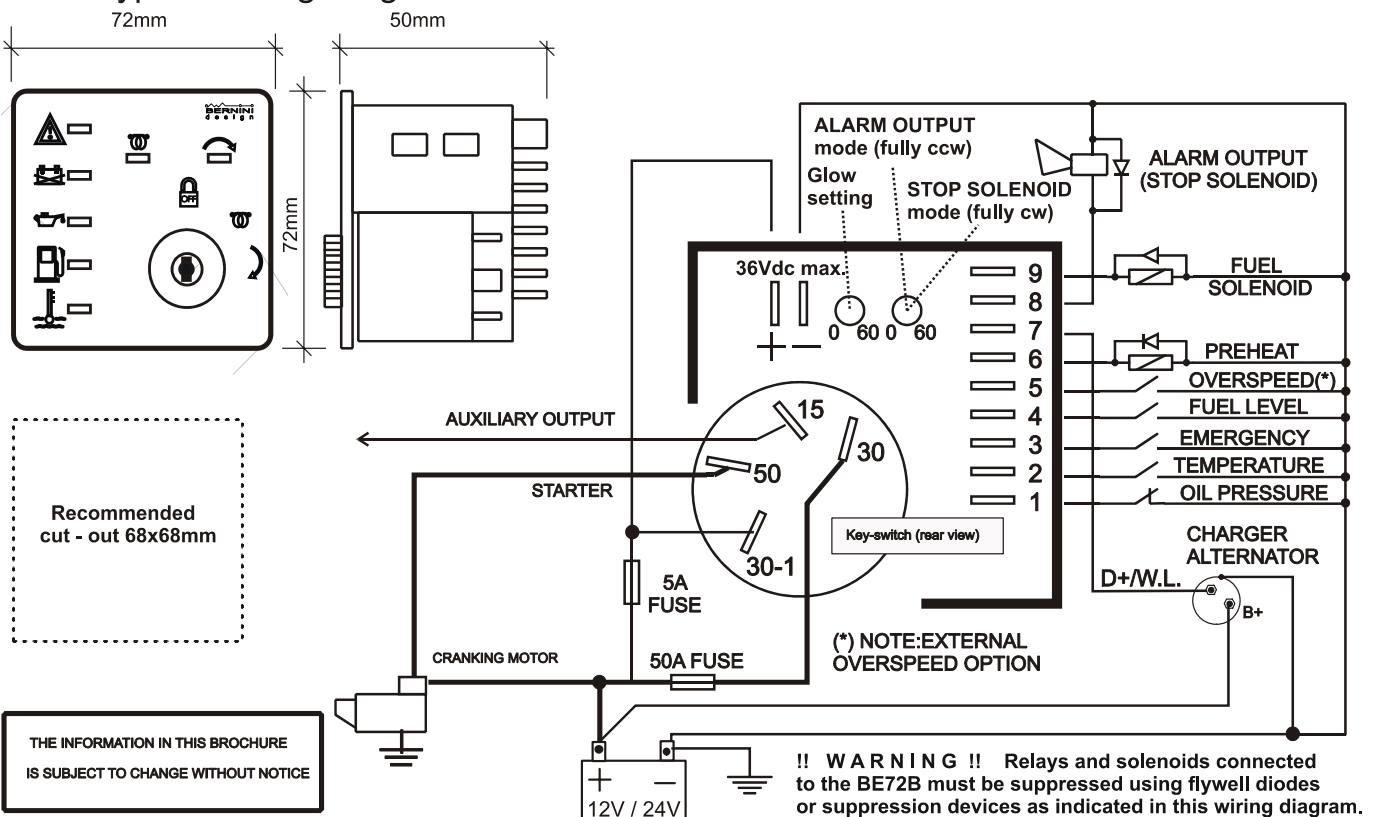

Recommended cut - out 68x68mm

THE INFORMATION IN THIS BROCHURE IS SUBJECT TO CHANGE WITHOUT NOTICE