

Standard functions

Engine control

- Start preparation (preheater or prelubrication)
- Start/stop sequences with selectable no. of start attempts
- Fuel solenoid selection (coil type)
- Idle speed control
- Local or remote start/stop
- Stop sequence with cool-down
- Running speed detection selectable
 - Charger alternator input (W terminal) or tacho generator
 - Binary input (D+)
 - Oil pressure based run detection
 - Generator voltage/frequency

Generator monitoring

- 3 or 1-phase generator monitoring
 - Voltage/current/frequency/power/reactive power

Generator protection (ANSI)

- Over-/undervoltage (27/59)
- Over-/underfrequency (81)
- Overcurrent (51)
- Reverse power (32)

Engine monitoring

- 3 configurable inputs
 - VDO or
 - 4-20 mA from active transducer or
 - Binary with cable supervision
- 6 binary inputs, configurable
- RPM input, selectable
 - Magnetic pick-up
 - NPN or PNP pick-up
 - Tacho generator
 - Charger alternator W terminal

Clear text display

- 122 x 32 pixel backlight STN
- Graphic symbol messaging
- Clear text alarm messages
- Clear text diagnostics for both hardwired inputs and CANbus messages (J1939)
- Log book holding 30 log entries
- Real time clock for time and date

Application

The Generator Controller GC-1M is a micro-processor based control unit containing all necessary functions for protection and control of a diesel engine. Furthermore, it contains a three-phase AC voltage measuring circuit. The unit is equipped with an LCD display presenting all values and alarms. GC-1M is a compact all-in-one unit designed for the following applications:

1. Automatic engine start/stop
2. Engine protection
3. Breaker control
4. Generator protection

Optional applications:

5. Automatic Mains Failure
6. CANbus J1939 engine communication

GC-1M automatically carries out a cyclical self test. If any errors are found, then the status relay output will deactivate (normally closed). In order to save battery power, the display can be set to switch off automatically after a given period of time.



For approved installations, care must be taken to comply with the rules. In certain cases, additional engine protection equipment may be required. If in doubt, contact the classification society in question.

The display will turn on again, if events or alarms take place, or if one of the push-buttons is activated.

Setup

Setup is easily done via a PC Windows® based utility software (password protected) using the RJ11/RS232 PC connection. The PC interface box RJ11/RS232 needed for this operation is optional equipment for GC-1M. The PC utility software offers additional features such as monitoring of all relevant information during commissioning, saving and downloading of settings and downloading of software updates. Furthermore, the most frequently used settings can be accessed via the display push-buttons (password protected).

Options

The options selected by the customer will be integrated in the standard GC-1M hereby securing the same user interface unaffected by whether the application needs a basic or a more complex generator controller.

Terminals

Terminal	Technical data	Description
4	Common for terminals 5-7	
5	VDO1, 4..20 mA, dig. inp.	Fuel level/configurable
6	VDO2, 4..20 mA, dig. inp.	Oil pressure/configurable
7	VDO3, 4..20 mA, dig. inp.	Water temp./configurable
8-9	Tacho input	Magnetic pick-up/PNP/NPN/tacho generator/charge alternator W terminal
10-11	Status out, 1A 30V DC/V AC	General status output for marine approvals
12	Common	Common for term. 13-18
13	Digital input term. 13	Start enable/configurable
14	Digital input term. 14	Remote start/configurable
15	Digital input term. 15	Charge alternator D+ (running)/configurable
16	Digital input term. 16	Overspeed/configurable
17	Digital input term. 17	Coolant temperature/configurable
18	Digital input term. 18	Oil pressure/configurable
23	Common	Common for term. 24, 25 and 32 and emergency stop*
24	NO relay output 1, 2A 30V DC/V AC	Horn
25	NO relay output 2, 2A 30V DC/V AC	Alarm/configurable
26	Power supply – (gnd)	
27	Power supply + 6...36V DC	
28-31	Not used	
32	NO relay output 3, 2A 30V DC/V AC	Start prepare/configurable
33-34	NO relay output 4, 8A 30V DC/V AC	Run coil/stop coil/configurable
35-36	NO relay output 5, 8A 30V DC/V AC	Starter (crank)/configurable
37	Generator L3 voltage	Voltage range 50-480V AC Ph-Ph value
38	Generator neutral voltage	
39	Generator L2 voltage	
41	Generator L1 voltage	
49-50	Generator breaker control relay, 2A 30V DC/V AC	

Terminal	Technical data	Description
53	I L3 s2	Generator current L3
54	I L3 s1	
55	I L2 s2	Generator current L2
56	I L2 s1	
57	I L1 s2	Generator current L1
58	I L1 s1	

Optional emergency generator control		
43	Mains L3 voltage	Voltage range 50-480V AC Ph-Ph value
45	Mains L2 voltage	
46	Mains neutral voltage	
47	Mains L1 voltage	
51-52	Mains breaker control relay, 2A 30V DC/V AC	Configurable
Optional CANbus engine interface		
1	CAN-L	CAN J1939 engine communication
2	CAN-GND	
3	CAN-H	

Available options

Option	Description	Type	Note
B	Generator protection		
B3	Emergency generator control - Generator and mains tie breaker control - Change-over (no synchronisation)	Software option	
H	Communication		
H5	CANbus J1939 - Detroit Diesel DDEC - John Deere JDEC - Deutz EMR - Volvo Penta D12 AUX - Scania DEC	Software option	
J	Cables		
J5	PI-1 converter box kit (for PC connection)	Hardware option	
K	Documentation		
K1	Installation Instructions and Reference Handbook (hard copy)	Other	
K2	CD-ROM with complete documentation	Other	
L	Gasket for IP54	Hardware option	

(ANSI# as per IEEE Std C37.2-1996 (R2001) in parenthesis).

Option B3 display layout

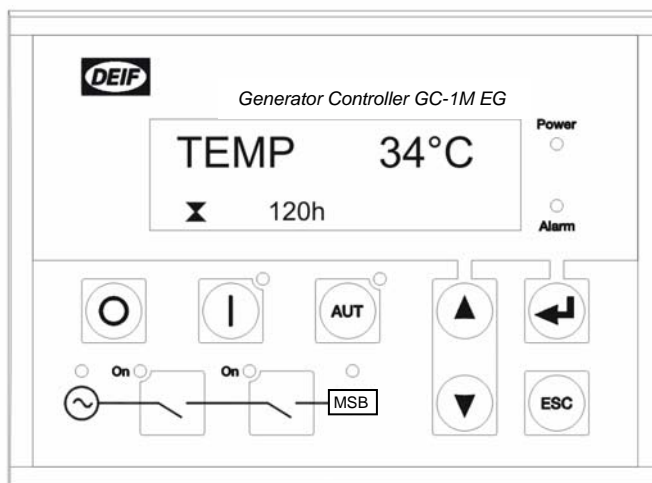

Wiring, engine interface



F: Fuse: 2A slow-blow.

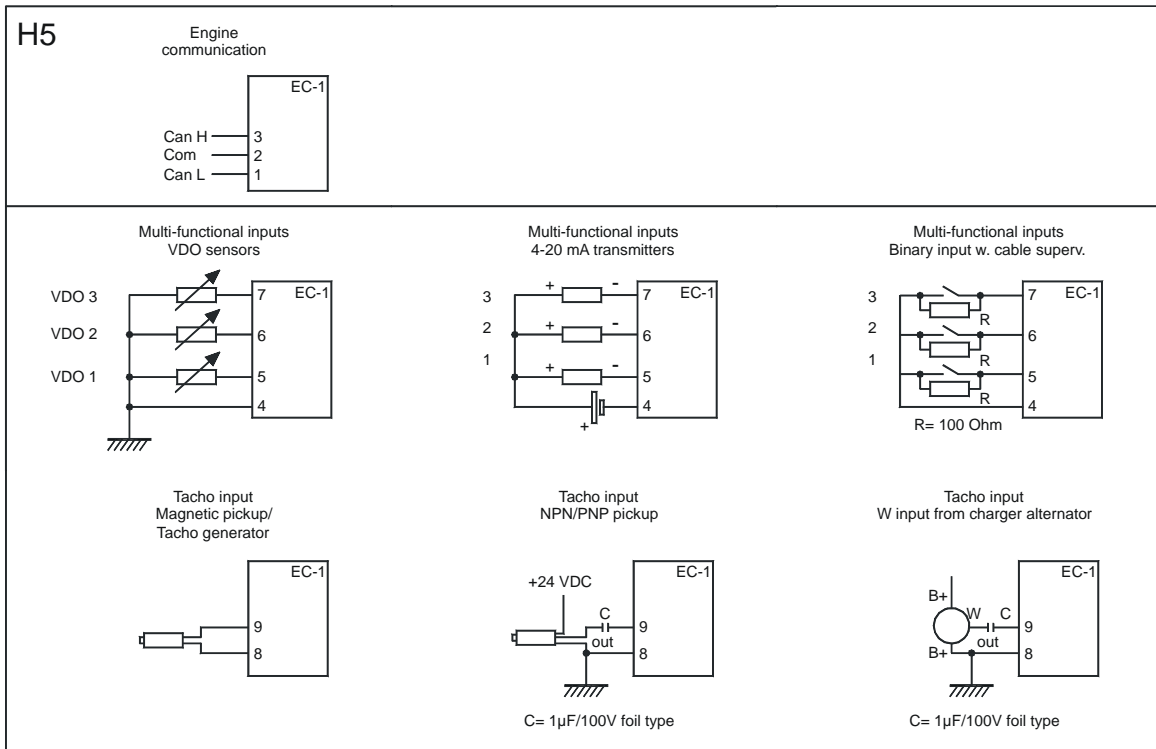
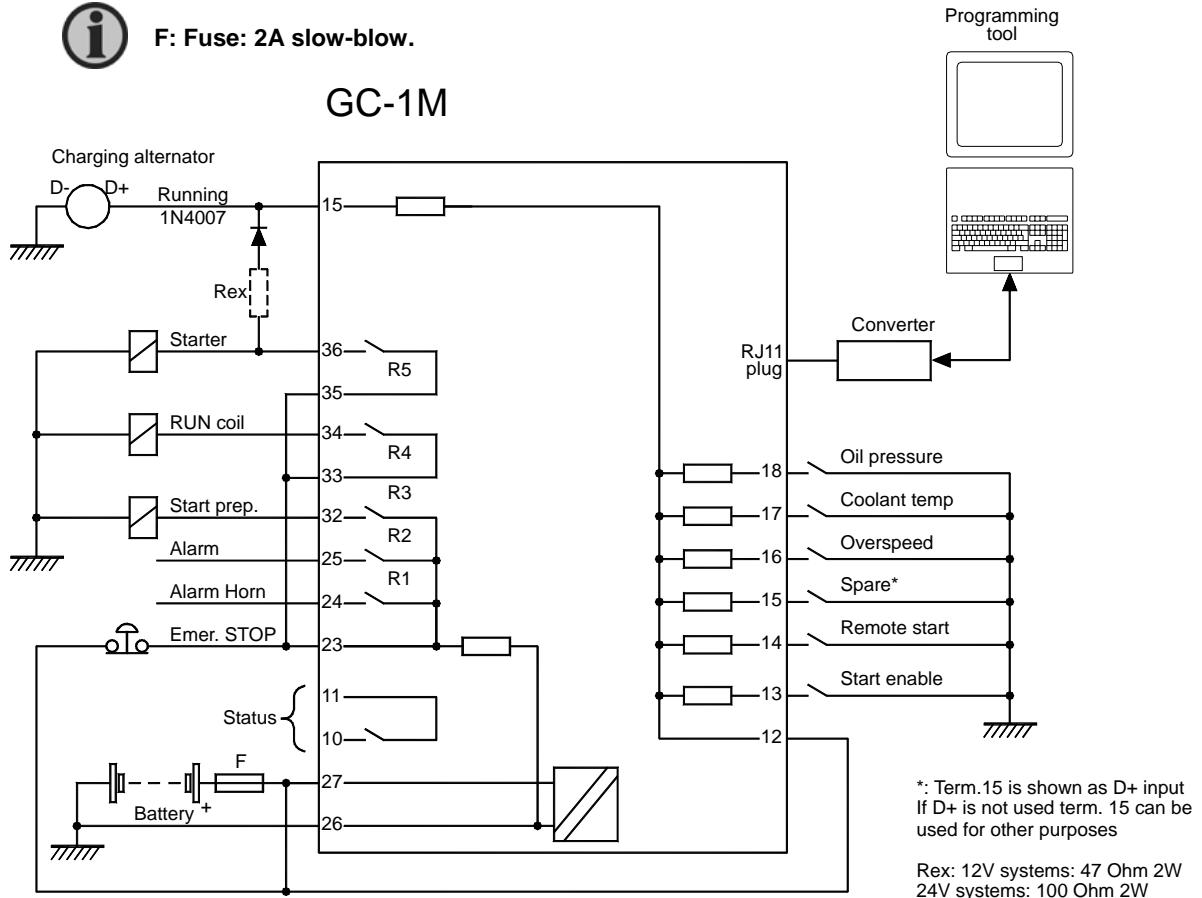

Wiring, AC interface

Connection of the 3-phase voltage and current

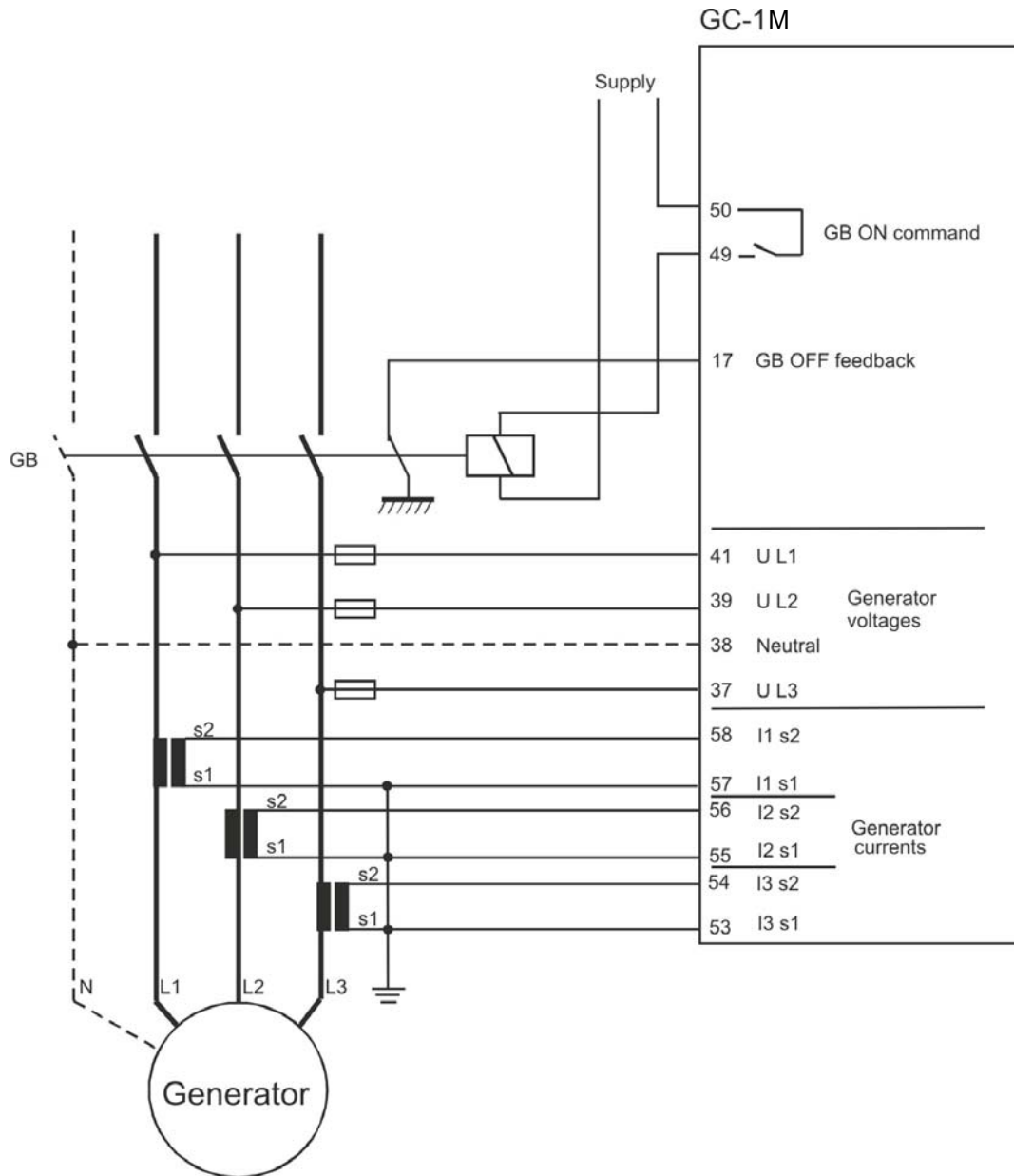

The AC current grounding can be made as required to s1 or s2.



GB: Use a contactor. The ON output from the GC-1M is a constant signal. Remember to use free-wheel diodes across the contactor coils, if DC voltage is used as supply for these.

Fuse for AC voltage: Max. 2A slow-blow.

Generator Controller (Marine) GC-1M

Wiring, EG (option B3)

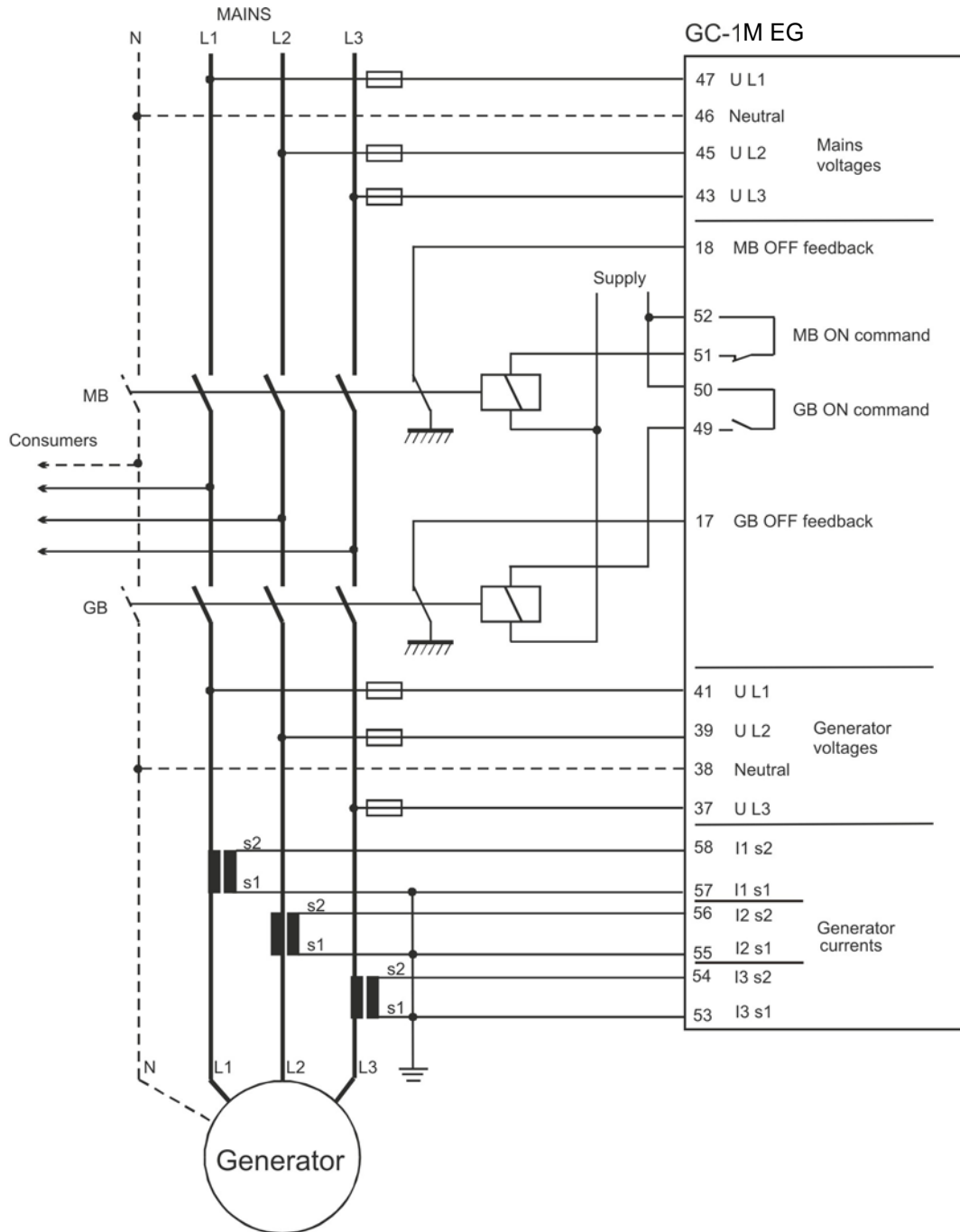

The AC current grounding can be made as required to s1 or s2.



GB and MB: Use contactors. The ON outputs from the GC-1M EG are constant signals. Remember to use free-wheel diodes across the contactor coils, if DC voltage is used as supply for these.

Fuse for AC voltage: Max. 2A slow-blow.

Technical specifications

Accuracy:	Class 2.0 to EN 60688/IEC 688	Relay outputs:	5 relays: 30V DC/AC 2A (UL/cUL Listed: 30V DC 2A resistive)
Operating temp.: (UL/cUL Listed:	-25...70°C (-13...158°F) Max. ambient temp. 40°C/104°F)	2 relays: 30V DC/AC 8A (UL/cUL Listed: 30V DC 4A resistive)	1 status relay: 24V DC 1A (UL/cUL Listed: 24V DC 1A)
Storage temp.:	-40...70°C (-40...158°F)	Mounting:	Panel mounted
Measuring input voltage: (UL/cUL Listed:	50...550V AC phase to phase 50...300V AC)	Size:	78 x 106 mm (3.07" x 4.17")
Load:	1.5 M Ω	Climate:	25...70°C to IEC 60068-2-1/2 97% RH to IEC 60068-2-30
Frequency:	30...70 Hz	Display:	122 x 32 pixel backlight STN
Measuring input current:	1 or 5A AC from current transformer	Safety:	To EN 61010-1, installation category (overvoltage category) III, 600 V, pollution degree 2
Consumption max.:	0.3 VA/phase	Protection:	Front: IP52 (IP54 with gasket, option L) Terminals: IP20 To IEC 529 and EN 60529
Current overload: (UL/cUL Listed:	10A continuously, 20A, 5 sec. Use listed or R/C (XODW2.8 current transformers))	EMC/CE:	To EN 61000-6-1/2/3/4 SS4631503 (PL4) and IEC 255-3
Pickup input voltage: Frequency:	0.5...70 V peak 10-10000 Hz	Material:	All plastic materials are self-extinguishing according to UL94 (V1)
Aux. supply: (UL/cUL Listed:	6...36V DC continuously 12/24V DC) Max. 8 W consumption	Plug connections:	AC voltage inputs: 3.5 mm ² multi-stranded AC current inputs: 4.5 mm ² multi-stranded Other: 1.5 mm ² multi-stranded
Passive binary in voltage:	Bi-directional optocoupler 8...36V DC	PC connection:	RS232 converter box (option J5)
Impedance:	4.7 k Ω	Approval:	UL/cUL to UL 508 Major classification societies (see www.deif.com for details)
VDO inputs:	Resistor inputs, internal 4 V supply	Weight:	Approx. 0.9 kg (1.9 lbs)
Analogue input:	From active transducer	UL markings:	
Current:	4...20 mA	Wiring:	Use 60/75°C copper conductors only AWG 30-12
Impedance:	50 Ω	Terminal tightening torque:	5-7 lb-in
Active binary in internal voltage:	Dry contact inputs (note 1) 4V DC supply, with cable supervision	Mounting:	For use on a flat surface of a type 1 enclosure
Impedance:	240 Ω ~ 16 mA	Installation:	To be installed in accordance with the NEC (US) or the CEC (Canada)



Only 3 inputs are available.



It is possible to combine VDO inputs with binary and 4...20 mA inputs in a mix.

Unit dimensions in mm (inches)

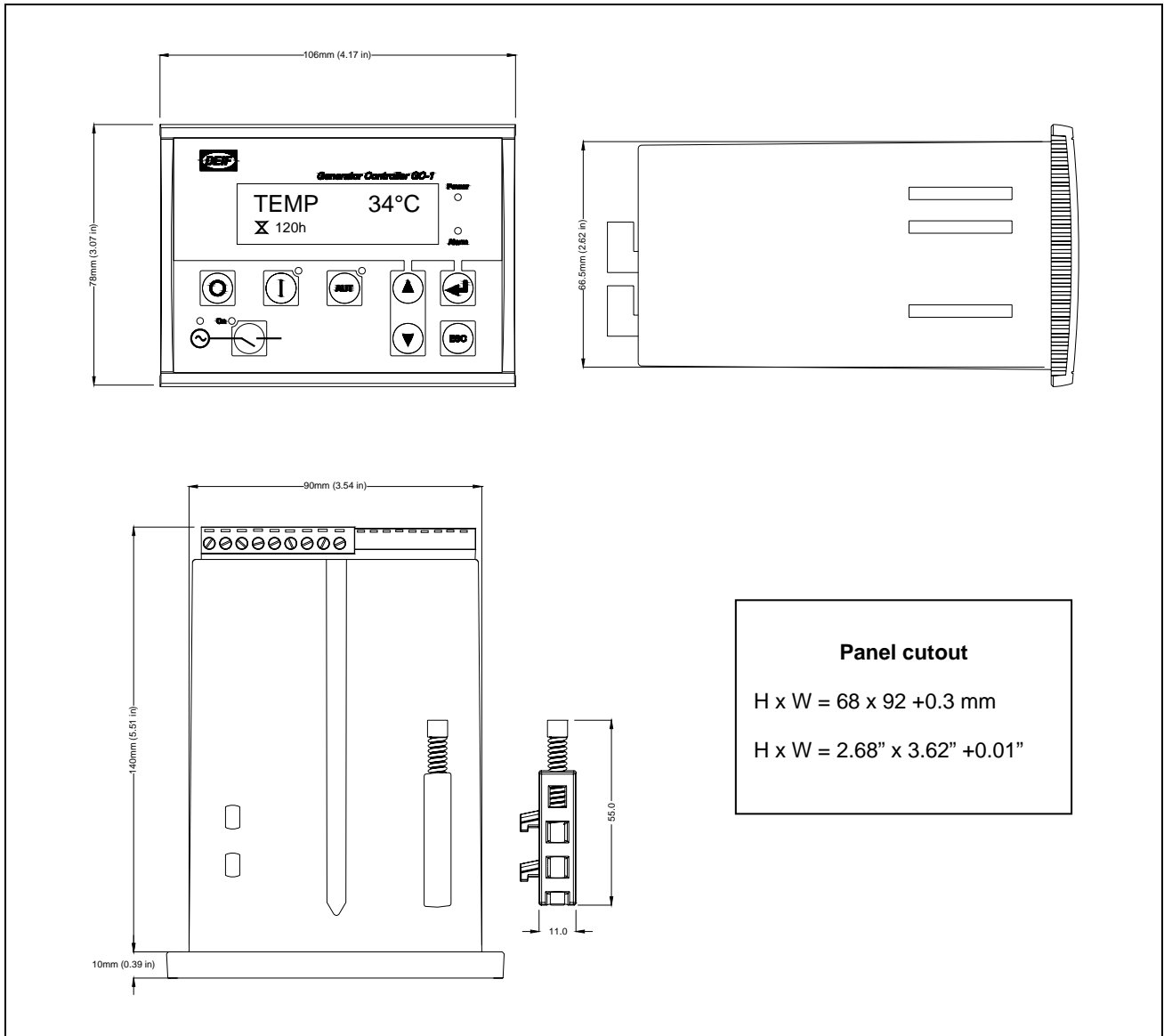

Order specifications

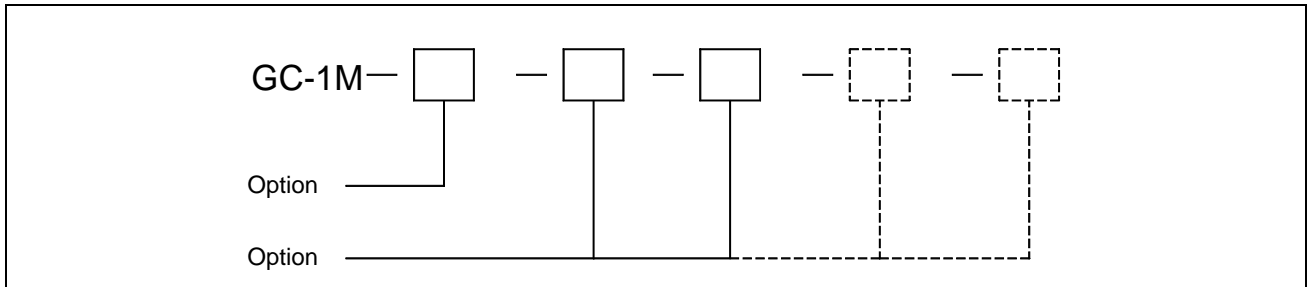

Due to our continuous development we reserve the right to supply equipment which may vary from the described.



DEIF A/S, Frisenborgvej 33
DK-7800 Skive, Denmark

Tel.: +45 9614 9614, Fax: +45 9614 9615
E-mail: deif@deif.com, URL: www.deif.com

