

InteliNano NT[®] AMF

Fast User Guide

Typical wiring diagram

Dimensions

Case dimensions: 118mm x108mm x 40mm
Panel Cutout: 96mm x 96mm

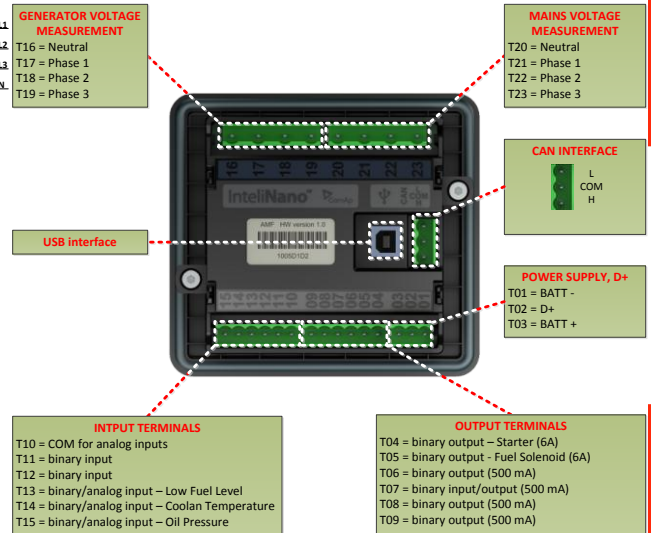
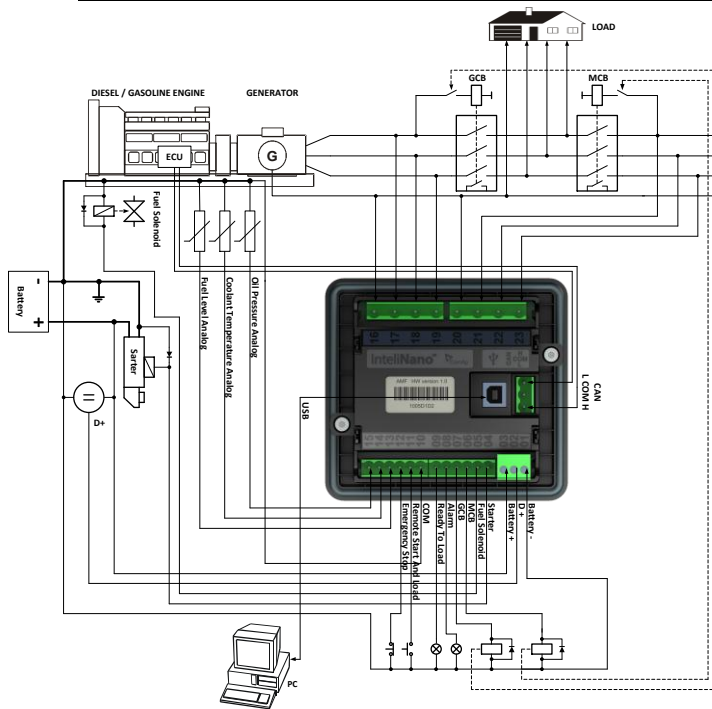

WARNING!
If D+ is not used, connect this terminal to battery positive!

Accessing the setup mode

Ensure the engine is stopped and the controller is in Manual mode (green LED above button **Auto** is turned off).

If you have not configured the custom initialization (init) screen then press and hold **Stop** button, then briefly press **▲** button and then **Auto**.

If you have already created your own init screen then press and hold **Stop** button and then briefly press **▲**, the custom init screen will appear, keep holding the **Stop** button. Then press **▼** to switch LCD to default init screen, and then press **Auto**.

To move up and down in the setup menu use **▲** and **▼** buttons. Press **Start** button to select or **Stop** button for exit.

	Basic settings		Output settings
	Engine parameters and protections		Input settings
	Generator protections		ECU setting
	AMF(Auto Mains Failure) settings		Info

Outputs and inputs





Output code	Output source	Type	Terminal assignment
O00	Not Used	binary	T04, T05, T06, T07, T08, T09
O01	Starter	binary	T04
O02	Fuel Solenoid	binary	T04, T05, T06, T07, T08, T09
O03	Stop Solenoid	binary	T04, T05, T06, T07, T08, T09
O04	Alarm	binary	T04, T05, T06, T07, T08, T09
O05	GCB Close/Open	binary	T04, T05, T06, T07, T08, T09
O06	MCB Close/Open	binary	T04, T05, T06, T07, T08, T09
O07	Ready To Load	binary	T04, T05, T06, T07, T08, T09
O08	Prestart	binary	T04, T05, T06, T07, T08, T09
O09	ECU Power Relay	binary	T04, T05, T06, T07, T08, T09
O10	Choke	binary	T04, T05, T06, T07, T08, T09
O11	Glow Plugs	binary	T04, T05, T06, T07, T08, T09

	Normally Open Contact – output		Normally Open Contact - input button
	Normally Closed Contact – output		Normally Closed Contact – input button

User curves			
	I21	I23	I25
	VDO Level %	VDO 5 Bar	VDO 40-120 °C
	Datcon Level %	VDO 10 Bar	VDO 50-150 °C
		Datcon 5 Bar	Datcon High °C
		Datcon 7 Bar	Datcon Low °C
		Datcon 10 Bar	
	Not selected	Not selected	Not selected

Input code	Input source	Type	Terminal assignment
I00	Not Used	binary	T07, T11, T12, T13, T14, T15
I01	Emergency Stop	binary	T07, T11, T12, T13, T14, T15
I02	Remote Start/Stop	binary	T11
I03	Remote Start And Load	binary	T11
I04	Access Lock	binary	T07, T11, T12, T13, T14, T15
I05	AMF Blocked	binary	T07, T11, T12, T13, T14, T15
I06	MCB Feedback	binary	T07, T11, T12, T13, T14, T15
I07	GCB Feedback	binary	T07, T11, T12, T13, T14, T15
I10	External Warning 1	binary	T07, T11, T12, T13, T14, T15
I11	External Warning 2	binary	T07, T11, T12, T13, T14, T15
I12	External Warning 3	binary	T07, T11, T12, T13, T14, T15
I13	External Shutdown 1	binary	T07, T11, T12, T13, T14, T15
I14	External Shutdown 2	binary	T07, T11, T12, T13, T14, T15
I15	External Shutdown 3	binary	T07, T11, T12, T13, T14, T15
I20	Low Fuel Level	binary	T07, T11, T12, T13, T14, T15
I21	Fuel Level Analog	analog	T13, T14, T15
I22	Low Oil Pressure	binary	T07, T11, T12, T13, T14, T15
I23	Oil Pressure Analog	analog	T13, T14, T15
I24	High Coolant Temperature	binary	T07, T11, T12, T13, T14, T15
I25	Coolant Temperature Analog	analog	T13, T14, T15

Setpoints

Use  and  buttons to move or change value.  button to select setpoint or confirm changes and  button to go back.

Basic settings		
Setpoint code	Setpoint name	
B01	Nominal Voltage Ph-N	80 – 480 V
B02	Nominal Voltage Ph-Ph	80 – 600 V
B03	Nominal Frequency	50 Hz (1), 60 Hz (2)
B04	Connection Type	Mono Phase (1), SplitPhase (2), 3Ph3Wire (3), 3Ph4Wire (4), Autodetect (5)
B05	Units Format	Metric unit format (1), US unit format (2)
B06	AMF Function	Disable (1), Enable (2)
B07	Zero Power Mode Delay	0-360 min
B08	Light Tower Mode	Disable (1), Enable (2)
B09	Nominal RPM	100-4000













Engine parameters and protections		
Setpoint code	Setpoint name	
E01	Prestart Time	0-600 s
E02	Maximum Cranking Time	0-60 s
E03	Cooling Time	0-3600 s
E04	Oil Pressure Shutdown	0-10 Bar
E05	Coolant Temperature Shutdown	0 -150 °C
E06	Battery Undervoltage	8 – 40 V
E07	Warning Maintenance	0 – 10000 h
E08	Oil Pressure Starter Disengagement	Disable (1), Enable (2)
E09	Choke Time	0 – 3600 s
E10	Minimal Stabilization Time	1 – 300 s









Generator protections		
Setpoint code	Setpoint name	
G01	Generator Overvoltage Shutdown	G02 – 200 %
G02	Generator Undervoltage Shutdown	0 - G01 %
G03	Generator Overfrequency Shutdown	G04 – 130 %
G04	Generator Underfrequency Shutdown	0 – G03 %



















AMF(Auto Mains Failure) settings		
Setpoint code	Setpoint name	
A01	Emergency Start Delay	0 – 600 s
A02	Mains Return Delay	1 – 3600 s
A03	Mains Overvoltage	A04 – 150 %
A04	Mains Undervoltage	50 – A03
A05	Mains Overfrequency	A06 – 150 %
A06	Mains Underfrequency	50 – A05 %

To apply all changes return to the main setup menu and restart the controller by pressing the  button.

Alarms and Events

Events	
	Mains Return
	Mains Fail
	Manual Start
	Remote Start
	AMF Start
	Manual Stop
	Remote Stop
	AMF Stop
	Auto On
	Auto Off
	Power On
	Island Operation

Warnings	
	Warning Maintenance
	Low Battery
	Low Fuel Level
	External Warning 1
	External Warning 2
	External Warning 3
	ECU Communication Error
	MCB Fail
	Mains CCW Rotation

Shutdowns	
	Emergency Stop
	Overspeed
	Underspeed
	Low Oil Pressure
	High Coolant temperature
	External Shutdown 1
	External Shutdown 2
	External Shutdown 3
	GCB Fail
	Generator Overvoltage
	Generator Undervoltage
	Generator Overfrequency
	Generator Underfrequency
	Generator CCW Rotation
	Start Fail
	Stop Fail
	Battery Flat
	Voltage Autodetect

ECU

For ECU configuration use PC software NanoEdit. For more details see IntelliNano AMF Reference Guide.

Technical data

Power supply range	6-36 VDC
Power supply drop-out immunity	100 ms
Power consumption	35 – 295 mA
Zero Power Mode consumption	52 - 344 µA

Operating temperature	-20... 70 °C
Operating humidity	95 % non-condensing (IEC/EN 60068-2-30)
Protection degree (front panel)	IP65 with GASKET 4x405 only IP50 without gasket
Storage temperature	-30... 80 °C

Binary outputs (up to 6)	
Low current outputs (4)	500 mA
High current output (2)	6 A (long term) / 10 A (short term)
Total output current	10 A (long term) / 16 A (short term)

Binary inputs (up to 6)	
Input resistance	1,5 kΩ
Closed contact voltage	<2 V
Open contact voltage	>3,5 V

Analog inputs (up to 3)	
Galvanic insulation	Not insulated
Electrical range	0 - 2500 kΩ
Resolution	0,1 Ω
Precision	2 % ± 3 Ω

Generator/Mains measurements	
Measurement input	3ph generator voltage, 3ph mains voltage
Measurement type	True RMS
Voltage range	480 V Ph-Ph (277 V Ph-N)
Max. measured voltage	340 V Ph-N
Voltage accuracy	1 %
Frequency range	40 – 70 Hz
Frequency accuracy	1 %

Charging alternator preexcitation circuit	
Excitation current	100 mA
Charging fail threshold	80 %