

Clarification of notation used within this manual:



WARNING

WARNING:

A **WARNING** indicates a potentially hazardous situation which, if not avoided, could result in death, serious personal injury or property damage.



CAUTION

CAUTION:

A **CAUTION** indicates a potentially hazardous situation which, if not avoided, could result in damage to equipment or property.



NOTE:

A **NOTE** provides other helpful information that does not fall under the warning or caution categories.



WARNING:

Read this entire manual pertaining to the work to be performed before installing, operating, or servicing this controller. Practice all plant and safety instructions and precautions. Failure to follow instructions can cause personal injury and/or property damage.

The engine or other type of prime mover should be equipped with an overspeed shutdown device to protect against runaway or damage to the prime mover with possible personal injury, loss of life, or property damage.

The overspeed shutdown device must be totally independent of the prime mover control system. An over temperature or low pressure shutdown device may also be needed for safety, as appropriate.



CAUTION—BATTERY CHARGING

To prevent damage to a controller that uses an alternator or battery-charging device, make sure the charging device is turned off before disconnecting the battery from the system.

Controllers contain static-sensitive parts. Observe the following precautions to prevent damage to these parts:

Do not disassemble the rear back of controller or touch the components and conductors on the printed circuit board.

Contents

1. Description	4
2. Outline Dimension Drawings and Controller Wiring.....	5
3. Panel Operation.....	8
4. Installation Guide	10
5. Control and Operation Instruction.....	10
6. Measure and Display Data.....	16
7. Pre-alarm and Shutdown Alarm.....	16
8. Parameter Settings	21
9. LCD Display and Menu System.....	29
10. Preparation before Starting the Controller	32
11. Technical Specification	32

1. Description

The GU610A is an Automatic Controller for generator. When running in “AUTO” mode, it starts the Genset after receiving remote start signal and on failure automatically stops the Genset. The generator’s controlling procedure and protection parameters can be modified, which fully meets the Genset’s requirements of automatic start, stop control and basic protection.

- The module displays fault conditions, operational status and related metering data on panel LCD.
- LCD has a backlight function so that the operator can read running parameters clearly even in the shadow.
- The controller has 2 modes: AUTO and MANUAL. Either can be chosen through the panel push button.
- Measures and displays generator’s output voltage, current, oil pressure, coolant temperature, frequency, DC source voltage, etc.
- True RMS measure of voltage and current, which ensures the data more accurate.
- Control the close/open of generator output switch.
- Equipped with built-in communication interface to configure parameters by PC.
- All connections of controller are connected by pin locked up terminals, easier and more convenient to connect, move, maintain and replace the device.

This manual is only suitable for GU610A Automatic Controller, user must carefully read this manual first.

2. Outline Dimension Drawings and Controller Wiring

2.1 Following Details:

Module Dimensions	W120mm×H102mm
Panel Cutout	W110mm×H92mm
Thickness	D48mm (without connection)

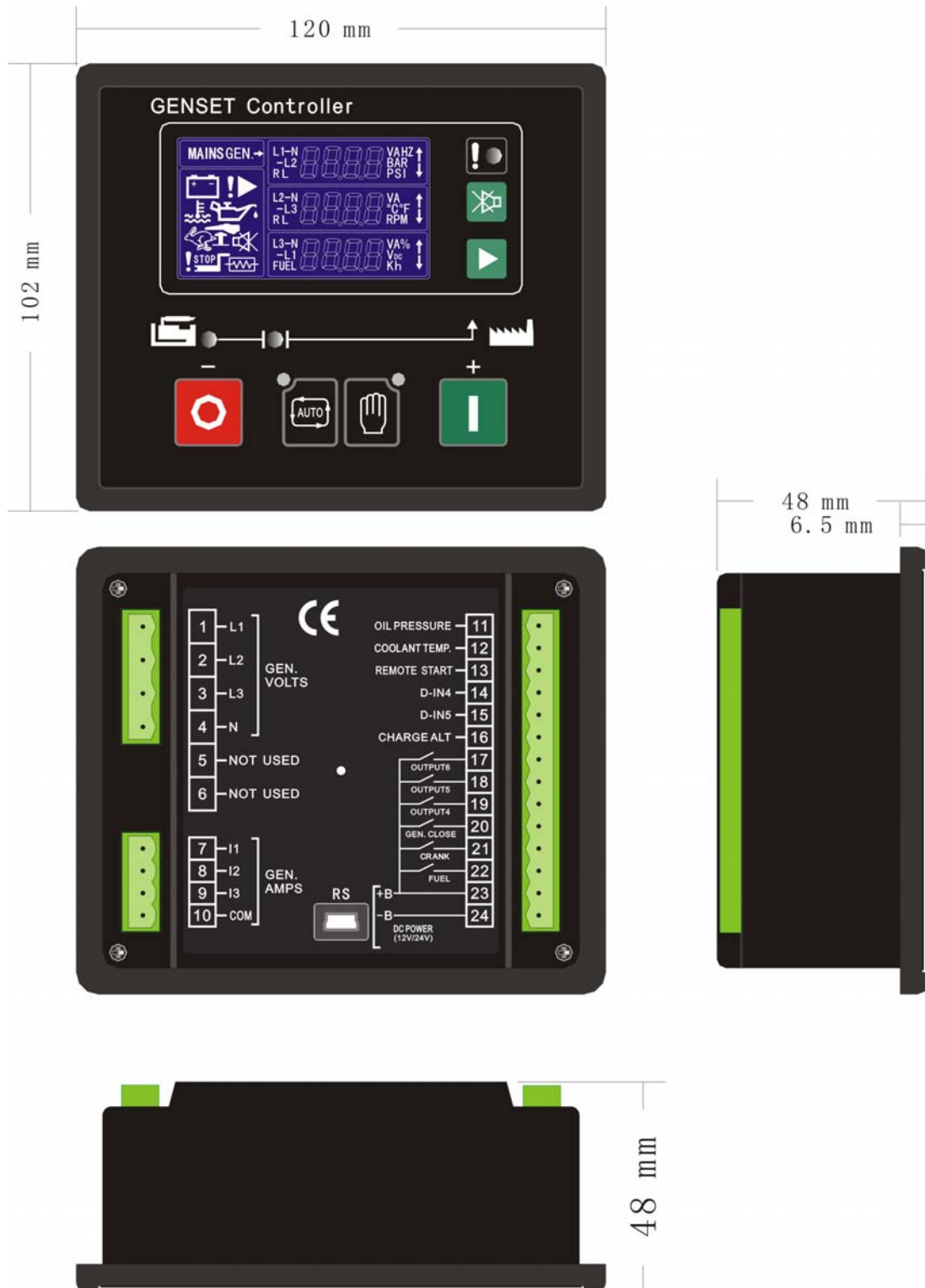

GU610A Controller Operation Manual

2.2 Terminal Connections:

Pin no.	Function Description	Signal	Dim
1	GEN. V_{L1-N} input	0-300Vac	1mm ²
2	GEN. V_{L2-N} input	0-300Vac	1mm ²
3	GEN. V_{L3-N} input	0-300Vac	1mm ²
4	GEN. Neutral		1mm ²
5	Not used		
6	Not used		
7	I1 Gen current input	0-5A	2.5mm ²
8	I2 Gen current input	0-5A	2.5mm ²
9	I3 Gen current input	0-5A	2.5mm ²
10	Common port for current input	0-5A	2.5mm ²
11	LOP sensor or switch signal	LOP sensor (<2K Ω)	1mm ²
12	HET sensor or switch signal	HET sensor (<2K Ω)	1mm ²
13	Configurable digital input signal 1	low level is active	1mm ²
14	Configurable digital input signal 2	low level is active	1mm ²
15	Configurable digital input signal 3	low level is active	1mm ²
16	Charge excitation power output	if not used, do not connect to negative	1mm ²
17	Configurable relay output 1	N.O. contact, 3A/30Vdc	1mm ²
18	Configurable relay output 2	N.O. contact, 3A/30Vdc	1mm ²
19	Configurable relay output 3	N.O. contact, 3A/30Vdc	1mm ²
20	GCB close/open relay output	N.O. contact, 3A/30Vdc	1mm ²
21	Start (Crank) relay output	N.O. contact, 3A/30Vdc	1mm ²
22	Fuel solenoid relay output	N.O. contact, 3A/30Vdc	1mm ²
23	Battery supply {+}	12V/24V (8-35Vdc continuous)	1mm ²
24	Battery supply {-}		1mm ²

2.3 Typical Wiring Diagram

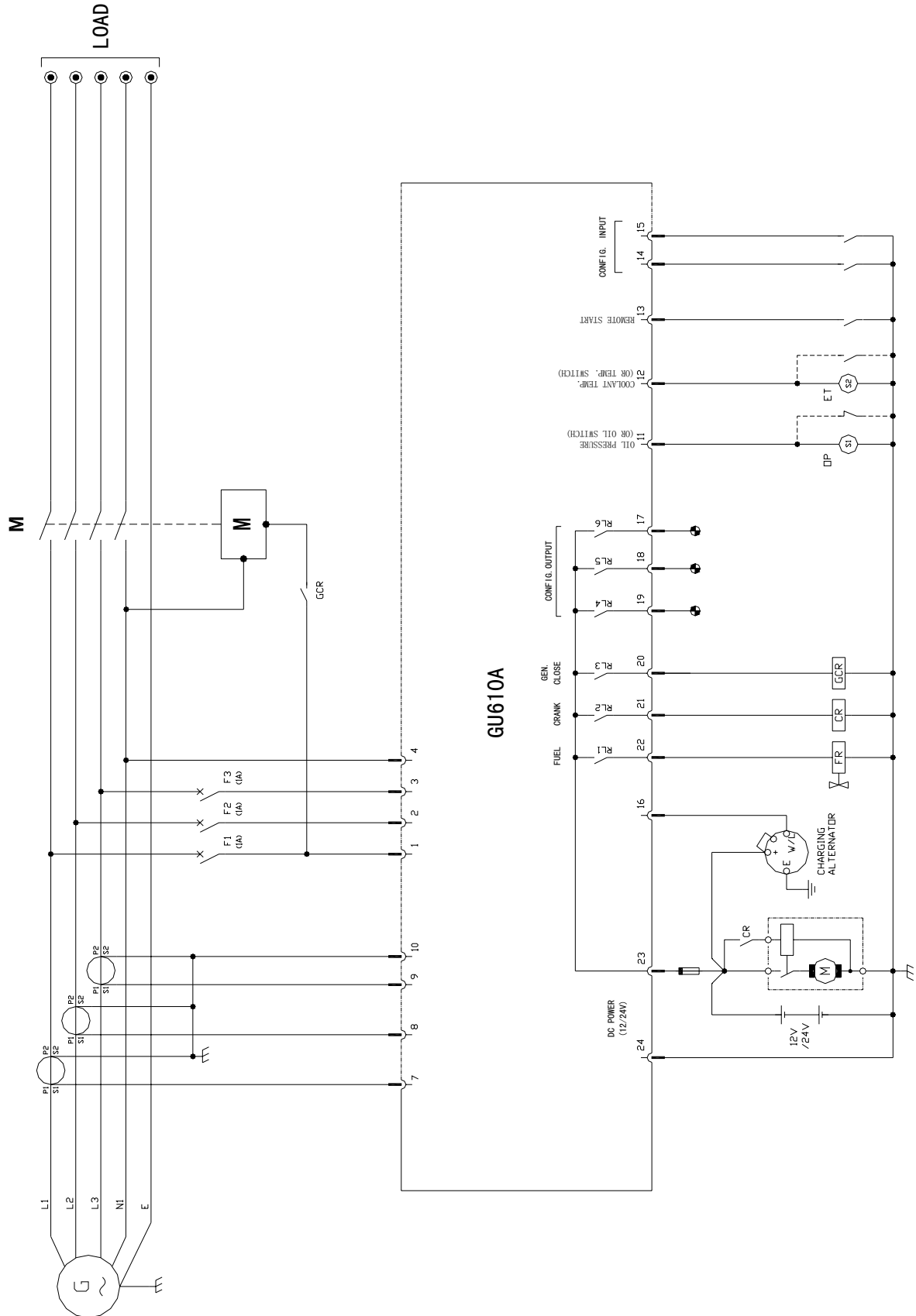





3. Panel Operation



The operation panel consists of 3 sections: LCD display measuring parameters, LED indicator for common failure, and push buttons for Genset and selection of control modes.

The LCD circularly displays different measuring parameters. When failure occurs, LCD displays the corresponding fault icon. LCD also has a backlight so that the operator can clearly read information day or night. After pressing any button the backlight will automatically turn off in a certain time.

The LCD display and its control push buttons provide a friendly operation interface for the operator to conveniently read information and set running parameters.

3.1 Control buttons and LED

Function Description	Tag
Scroll Push Button Enter into submenu / Modify / confirm modification / scroll menu to display.	
MUTE / LAMP TEST Push Button When failure occurs, alarm buzzer sounds. Pressing mute button will mute the sound. LCD displays mute icon. Press and hold mute button for 2sec, all LED illuminate simultaneously.	
AUTO Push Button / LED The push button is used for selecting "AUTO mode". When the controller is running in AUTO mode, the LED above the push button illuminates. The activation and deactivation of the "remote start signal input" controls the starting and stopping of the Genset.	
MAN Push Button / LED The push button is used for selecting "MAN mode". When the controller is running in MAN mode, the LED above the push button illuminates. The Start and Stop push buttons control the starting and stopping of the Genset.	
START / VALUE INCREASE "+" Push Button The push button is used for MANUALLY starting the Genset. When the controller is in MAN mode, press this push button will start the generator. When in parameter setting mode, this push button is used to increase values.	

<p>STOP / RESET / VALUE DECREASE “-” Push Button The push button is used to MANUALLY stop the Genset. When the controller is in MAN mode, press and hold this button more than 2sec to stop the Genset.</p> <p>If failure occurs, press this push button, the shutdown alarm lockout will be cleared.</p> <p>When in parameter setting mode, this push button is used to decrease values.</p>	
<p>COMMON FAILURE LED LED will flash when pre-alarm (Warning) occurs. LED will illuminate permanently when shutdown alarm occurs.</p>	

4. Installation Guide

4.1 The cutout dimensional drawing installed on panel as above attached.

The controller is secured by 2 special fittings. The shock-proof equipment must be installed if the enclosure that installed on controller is directly installed on Genet body or other heavy vibrant device.

4.2 Please read above Typical Wiring Diagram fig 2.3 for wiring connections.

4.3 Installation of engine LOP and HET sensors:

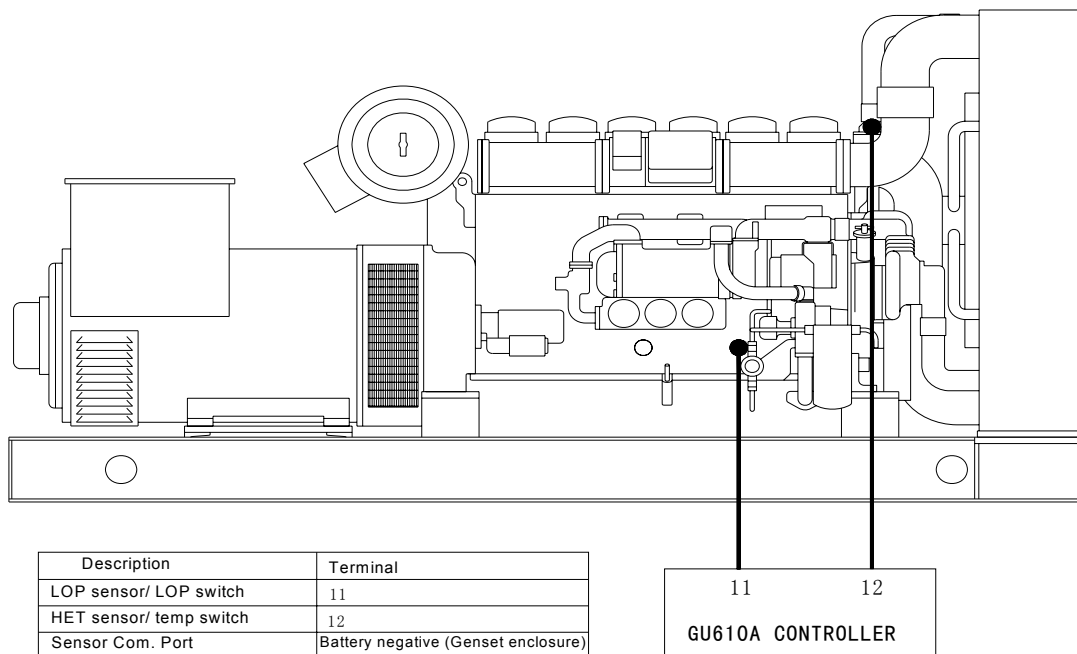

5. Control and Operation Instruction





CAUTION:

- Pin no. “11” and “12” is for “LOP sensor or switch signal” and “HET sensor or switch signal” input respectively. Either switch or sensor can be chosen. When sensor is used, according to the actual situation, increase the cross section area of cable to reduce the cable resistance from controller to engine, which ensures the accuracy of measured values for both oil pressure and engine temperature.
- If both switches and sensors are required for oil pressure and engine temperature, connect Pin no. “11” and “12” as above, and connect 2 configurable inputs to the switches of oil pressure and temperature, then configure parameters by setting.

The controller has 2 modes: AUTO and MAN.

5.1 Operation Mode Setting:

Operation	Description
Press "AUTO" button (continuous 2sec) When controller is running in "AUTO" mode, LED above push button illuminates.	
Press "MAN" button (continuous 2sec) When controller is running in "MAN" mode, LED above push button illuminates.	

NOTE: Only one mode of above 2 modes can be selected.

5.2 AUTO control Sequence:

Controller is in "AUTO" mode.

First of all, define one of the configurable inputs as **Remote Start Signal**.

When the remote start signal is active, the controller implements following procedure:

The Start delay timer begins to count, when it times out the Preheat relay output is energized (if preheat function is selected), the timer starts. When it times out, the fuel relay output is energized, and operates the fuel solenoid of the engine. After 300ms delay, the start (crank) relay output is energized; the start motor engages and begins to crank. When the engine speed reaches the crank cutout RPM, the start relay output is de-energized and the safety-on delay starts. When the safety-on times out, if the controller detects that the parameters of the Genset such as voltage, frequency, oil pressure, coolant temperature are normal, and no other failure is detected this indicates the Genset has successfully started and running normally. The LCD displays the Genset measuring parameters.

When the voltage and frequency of Generator is normal, Gen. Normal LED illuminates, the timer for Gen. On delay is activated, when it times out, GCB close/open relay closes, then the transfer switch switches on Gen. The Gen Aux. Switch's contact feeds back a signal to a configurable input on our controller. GCB closed LED illuminates.



NOTE:

- When the remote start signal is active, the start delay timer starts. During this period, if remote start signal is deactivated, the start delay timer is immediately terminated; the controller will recover to its original standby status.
- During the period of crank or idle, if remote start signal is deactivated, controller stops the start procedure and recovers to original standby status.



NOTE:

- While cranking, engine ignites. The start motor will power off when the output frequency of generator reaches the preset value (configurable crank cutout value), or if there are one of the following conditions occur:
 - A. Generator's voltage reaches 80% of rated voltage;
 - B. Cranking time's up,
 - C. LOP switch is opened and the delay time's up.
- Controller can not implement crank procedure if the frequency of generator reaches the preset value (configurable cranking cutout value) or LOP switch is opened.



CAUTION:

To avoid damage to the start motor please make sure the generator's voltage is higher than 15V (measurable voltage of the controller) while cranking, since the crank cutout signal is sensed from the generator voltage and frequency.



NOTE:

Above control procedure, assumes that one of configurable inputs has been configured as **Gen Aux. Switch Closed** and connects the switch's N.O. Aux. contact signal to this port. If you do not configure an input as **Gen Aux. Switch Closed**, then the GCB closed LED illuminates is only an indication that the GCB close/open relay should have been closed.

If you have selected idle function, the idle relay will be closed at the same time as the crank relay is closed. The timers of idle and safety-on delay will begin counting down at the same time, and in priority to display the shorter one on the LCD, and the following procedure is the same as above.

During the crank period, if the engine can not ignite and controller will not output start signal during crank rest, Fail to Start icon on LCD flashes at this time. Once crank rest timer times out the start relay energizes once again and will attempt to start engine again.

The procedure above will be repeated until engine successfully ignites or reaches the preset number of crank attempt. However, if any failure occurs during crank, controller will stop cranking immediately and only can be reused after clearing failure and reset.

Fail to Start: when the above procedure repeats again and again and reaches the preset number of crank attempt, the crank relay output is then de-energized. The common failure LED illuminates and the LCD displays **Fail to Start** icon.



CAUTION:

If Fail to Start occurs, operator must check the whole Genset system to find reason for failure, only after clearing the failure can press “STOP/RESET” button to relieve fault lock out status, and restart the Genset.

Generator shutdown sequence:

When the remote start signal is de-activated, the cool down delay timer begins to count. When it times out, the fuel relay output de-energizes, open the fuel solenoid immediately, generator stops and goes to standby status.

Fail to stop: When cool down times out, the fuel relay output de-energizes, stop delay timer begins. When it times out, if controller detects that the voltage and frequency of generator or oil pressure of engine are greater than the preset values, the common failure LED illuminates and the LCD displays **Fail to stop** icon.



NOTE:

After stop failure, the controller will not energize the crank relay output if the failure hasn't been removed and the controller reset.

5.3 MANUAL control sequence:

Controller is in “MAN” mode.

Generator starting sequence:

Press “START” push button, the fuel relay output is energized, and operates the fuel solenoid of the engine. After 300ms delay, the start relay output is energized, the start motor engages and begins to crank. When the engine speed reaches the crank cutout RPM, the start relay output is de-energized and the safety-on delay starts. When it times out, if the controller detects that the parameters of the Genset such as voltage, frequency, oil pressure and coolant temperature are normal, and no other failure is detected this indicates the Genset has successfully started and running normally. The LCD displays the Genset measuring parameters.

When generator is running normally, GCB close/open relay will not close automatically. Manually close the Gen switch, Gen is on load, the Gen Aux. Switch's contact feeds back the signal to a configurable input on our controller, Gen. Normal LED illuminates.



NOTE:

When the controller is in “MANUAL” mode and Gen. Normal LED illuminates, you must define one configurable input as **Gen Aux. Switch Closed** and connect the switch's N.O. Aux. contact signal to this port, otherwise the GCB closed LED will not illuminate.

5.4 The start and stop sequence of engine whose fuel solenoid is N. O. type (energize to stop):

Start control sequence:

During the starting sequence, the fuel output relay of controller will not energize, fuel solenoid is no power, so no signal is required for fuel solenoid to activate.

Stop control sequence:

During the stopping sequence, the fuel relay output energizes, the fuel solenoid is on power and energizes, and the engine begins to stop. After a delay (same as stop delay) fuel relay de-energizes, cutting off the supply for the fuel solenoid.

Other control sequence is same as engine whose fuel solenoid is N. C. type (energize to run).

5.5 Idle function:

For **idle** function configure one of the configurable outputs as **idle**.

Refer to the flow chart **5.7** for start and stop for **idle** control flows.

5.6 Preheat function:

For **Preheat** function, configure one of the configurable outputs as **Preheat**. The controller has 3 selectable preheat control modes as below:

Mode 1 — during preheat time, preheat relay output energizes.

Mode 2 — during preheat time, preheat relay output energizes until the successful ignition.

Mode 3 — during preheat time, preheat relay output energizes until safety-on delay times out.

During crank period, the Preheat relay output will not energize in any of above modes.

Refer to the flow chart **5.7** for start and stop for **Preheat** control flows.

When the Preheat relay output energizes, LCD displays the icon of preheat operating status:



5.7 Flow chart for start and stop

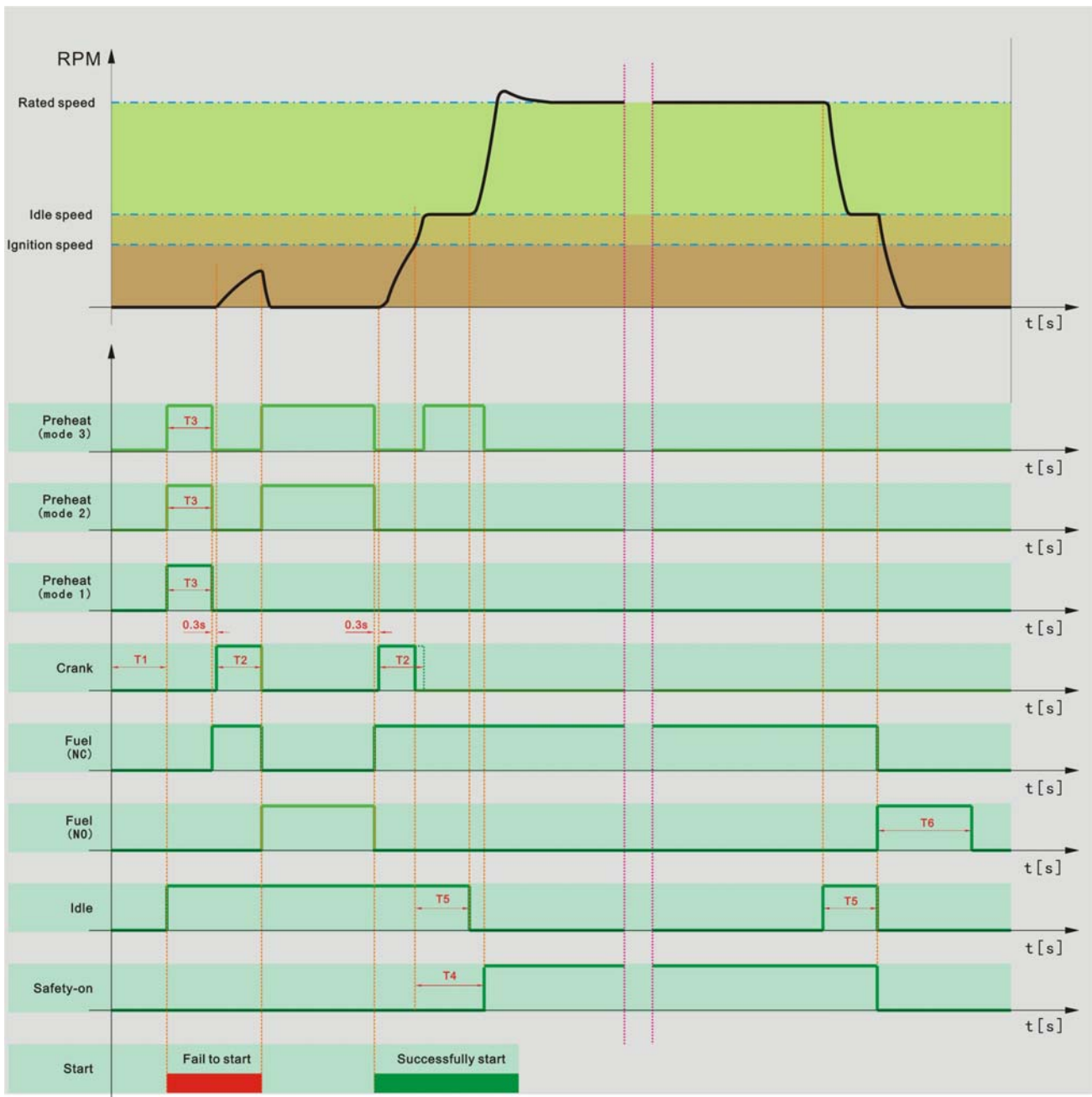

- | | |
|--------------------|----------------------|
| T1 — start delay | T4 — safety-on delay |
| T2 — crank time | T5 — idle time |
| T3 — pre-heat time | T6 — stop delay |



NOTE:

If T4 is longer than T5, low oil pressure protection is ignored during T5.

If T4 is shorter than T5, low oil pressure protection becomes effective after T4 in T5.

6. Measure and Display Data

Gen phase voltage **L1-N L2-N L3-N**

Gen line voltage **L1-L2 L2-L3 L3-L1**

Generator current **I1 I2 I3**

Generator frequency **Hz**

Engine speed **RPM** (derived from generator frequency)

Engine oil pressure **BAR / PSI** (signal from engine LOP sensor)

Engine coolant temperature **°C/°F** (signal from engine HET sensor)

Battery voltage **Vdc**

Running hours **h**

7. Pre-alarm and Shutdown Alarm

7.1 Pre-alarm (Warning)

NOTE: (Pre-alarms (Warnings) are non-critical failure conditions and do not affect the operation of the generator system, they serve for drawing the operators' attention to an undesirable condition so they can remove it to ensure continuous running of the system. When Pre-alarms occur, the LED indicator flashes, but failure will not be locked out and the unit will not shutdown. Once the Pre-alarm failure is removed the Pre-alarm LED will automatically turn off.)

Pre-alarm / Description	LCD Display
<p>Fail to Charge: After safety-on times up, if the charging voltage from the excitation contact of alternator is lower than the “charge V Pre-alarm”, the common failure LED indicator () flashes, the LCD displays Charge failure icon:</p>	
<p>Battery Low Voltage: if controller detects that battery voltage has fallen below the “low batt. pre-alarm”, common failure LED indicator flashes. For example, “low batt. pre-alarm” preset as: 23.6V, when battery voltage falls below this value, LCD flashing low value icon:</p>	
<p>Battery High Voltage: if controller detects that battery voltage has exceeded the “high batt. pre-alarm”, common failure LED indicator flashes. For example, “high batt. pre-alarm” preset as: 28.2V, when battery voltage exceeds this value, LCD flashing high value icon:</p>	
<p>Low Oil Pressure: if controller detects that the engine oil pressure has fallen below the “low oil-press pre-alarm” after the safety-on timer expired, common failure LED indicator flashes. For example, “low oil-press pre-alarm” preset as: 2.2BAR, when engine oil pressure falls below this value, LCD flashing low value icon:</p>	

GU610A Controller Operation Manual

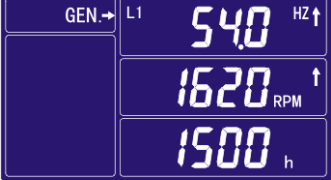
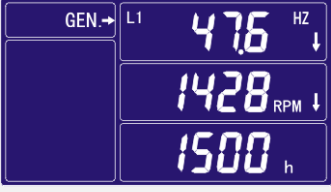
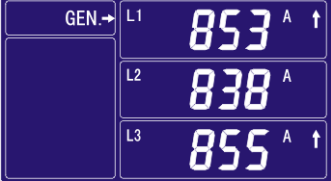
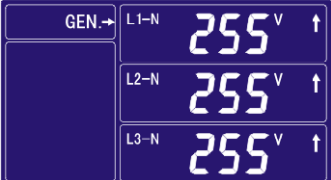
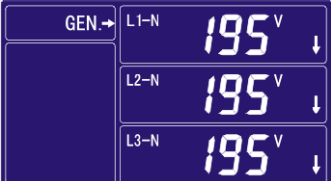
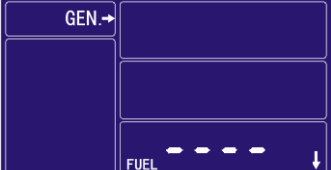
<p>High Temperature: if controller detects that engine coolant temperature has exceeded the “high temp pre-alarm”, common failure LED indicator flashes. For example, “high temp pre-alarm” preset as: 95°C, when engine coolant temperature exceeds this value, LCD flashing high value icon:</p>	
<p>Over speed: if engine speed exceeds the “over speed pre-alarm”, common failure LED indicator flashes. For example, “over speed pre-alarm” preset as: 1600RPM, when engine speed exceeds this value, LCD flashing high value icon:</p>	
<p>Under speed: if engine speed falls below the “under speed pre-alarm” after the safety-on timer has expired, common failure LED indicator flashes. For example, “under speed pre-alarm” preset as: 1440RPM, when engine speed falls below this value, LCD flashing low value icon:</p>	
<p>Over Current: if any phase output current of generator exceeds the “over current pre-alarm” after the safety-on timer has expired, common failure LED indicator flashes. For example, “over current pre-alarm” preset as: 850A, when any phase output current of generator exceeds this value, LCD flashing high value icon for corresponding phase:</p>	
<p>High Voltage: if controller detects that any phase output voltage of generator has exceeded the “Vac high pre-alarm” after the safety-on timer has expired, common failure LED indicator flashes. For example, “Rated ph-voltage” preset as: 220V, “Vac high pre-alarm” preset as: 115%, when any phase output voltage of generator exceeds this value, LCD flashing high value icon for corresponding phase:</p>	
<p>Low Voltage: if controller detects that any phase output voltage of generator has fallen below the “Vac low pre-alarm” after the safety-on timer has expired, common failure LED indicator flashes. For example, “Rated ph-voltage” preset as: 220V, “Vac low pre-alarm” preset as: 90%, when any phase output voltage of generator falls below this value, LCD flashing low value icon for corresponding phase:</p>	
<p>Low Fuel Level: If a configurable input has been defined as low fuel level, when the input signal is active, common failure LED indicator flashes, LCD displaying low fuel level icon:</p>	

GU610A Controller Operation Manual

Auxiliary Pre-alarm: if a configurable input is defined as pre-alarm, when the input signal is active, common failure LED indicator flashes. LCD displaying Aux. pre-alarm icon:

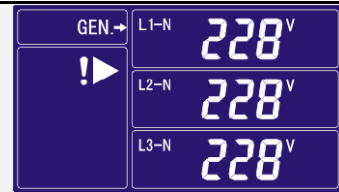

NOTE:

To make “low oil pressure” and “high temperature” pre-alarm active, you must use LOP sensor and HET sensor, if you only use LOP and HET switches, both pre-alarms are inactive.



NOTE:

Controller continuously detects battery voltage during standby and **Battery Low/High Voltage** pre-alarms are active. **Battery Low Voltage** pre-alarm is inactive during cranking.



CAUTION:



Under the period of safety-on delay, some pre-alarms (e.g.: under speed, low voltage and low oil pressure) are inactive, the safety-on delay must be carefully and properly set to make Genset have full protection.

7.2 Shutdown Alarm

NOTE: (shutdown alarm failures immediately lock out the system and stop the Genset. The failure must be removed and the controller be reset before restarting the Genset.)

Shutdown Alarm / Description	LCD Display
Fail to Start: if engine does not fire after the preset number of crank attempt has been made, common failure LED illuminates. LCD displays “fail to start” icon:	
Fail to Stop: if engine does not stop after the stop delay expired, common failure LED illuminates. LCD displays “fail to stop” icon:	
Emergency Stop: define a configurable input as emergency stop, when the input signal is active, controller immediately stops all relay control outputs except alarm, engine stops immediately. Common failure LED illuminates, LCD displays “emergency stop” icon:	

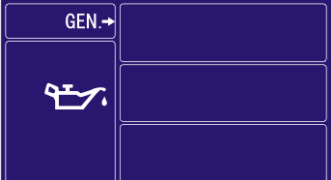
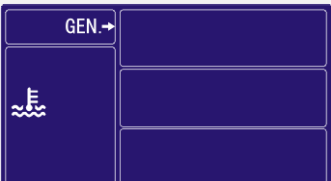
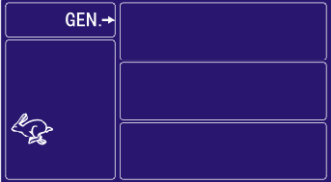
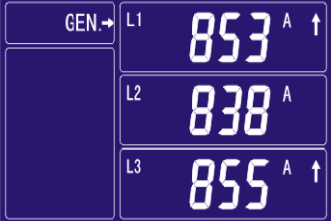
GU610A Controller Operation Manual

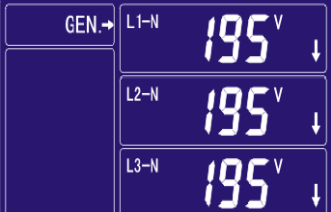
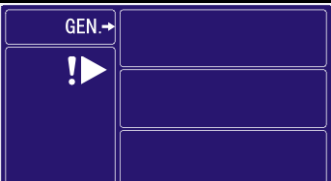
<p>Low Oil Pressure: if controller detects that the oil pressure still falls below “low oil-press alarm” or LOP switch closes after the safety-on timer has expired, engine stops immediately, common failure LED illuminates. LCD displays low oil pressure icon:</p>	
<p>High Temperature: if controller detects that engine coolant temperature has exceeded the “high temp alarm” or HET switch closes, engine stops immediately, common failure LED illuminates. LCD displays high temperature icon:</p>	
<p>Over speed: if controller detects that engine speed exceeds “over speed alarm”, engine stops immediately, common failure LED illuminates. LCD displays over speed icon:</p>	
<p>Over Current: After safety-on delay time up, if controller detects that any phase output current of generator exceeds the “over current alarm”, the engine will be shut down immediately, common failure LED illuminates.</p>	
<p>High Voltage: After safety-on delay times up, if controller detects that one of the phase voltage exceeds the “Vac high alarm”, the engine will be shut down immediately, common failure LED illuminates.</p>	
<p>Low Voltage: After safety-on delay times up, if controller detects that any phase output voltage is lower than the “Vac low alarm”, the engine will be shut down immediately, common failure LED illuminates.</p>	
<p>Auxiliary Failure: If a configurable input has been defined as Shutdown Alarm, when the input signal is active, common failure LED illuminates. LCD displays Aux. shutdown alarm icon:</p>	

Code Table for Failure:

Name	Code
CHARGE FAILURE	8888
BATT. UNDER VOLT	8888
BATT. OVER VOLT	8888
START FAILURE	8888
STOP FAILURE	8888
EMERGENCY STOP	8888
LOW OIL PRESS	8888

Name	Code
ENGINE HIGH TEMP	8888
OVER SPEED	8888
UNDER SPEED	8888
OVER CURRENT	8888
GEN. OVER VOLT	8888
GEN. UNDER VOLT	8888
P-SENSOR OPEN	8888



NOTE:

- Engine speed signal is derived from the frequency of generator output voltage, it is used for control and failure protection parameters, for the convenience of user, some data is expressed by RPM, $RPM = Hz * 60 / \text{pair of poles}$.
- While the Genset is running, if there are high coolant temperature, low oil pressure or over speed failure occurs, the controller will shutdown it immediately without delay. During the cool down period, if there is low oil pressure failure, the alarm will be active no matter if there is idle function.



CAUTION:

During the period of safety-on delay, low oil pressure protection is inactive. To avoid starting an engine with no oil, you must make sure the oil levels are normal and the safety-on delay shall be carefully and properly set for the first commissioning.

8. Parameters Setting

8.1 System Parameters:

NO.	Items		Preset	Value Range
1.1	CT ratio		100	1-2000
1.2	VT ratio		1.0	1.0-100.0
1.3	Rated ph-voltage		220	45-9999Vac
1.4	AC voltage type		3	1,3 (3 for 3 phase 4 wire, 1 for signal phase 2 wire)
1.5	Startup mode		0	0-1 / 0 (MAN) / 1 (AUTO)
1.6	Oil pressure unit		0	0-1 (0-BAR,1-PSI)
1.7	Temperature unit		0	0-1 (0-°C,1-°F)
1.8	Communication address		1	1-247
1.9	Default settings			
1.10	On-line update			
1.11	Page scroll time		0S	0-10 S / 0 (not used)

NOTE:



- **For 1.5 Startup Mode**, if you select “1”, the controller will be in AUTO mode when it is powered on; if you select “0”, the controller will be in MAN mode when it is powered on.
- After the oil pressure and temperature units changed, the corresponding failure alarm value must be reset according to actual situation.
- Engine speed is calculated by the number of “pair of poles”. $RPM = Hz * 60 / \text{pair of poles}$, when rated frequency is 50 Hz, if pair of poles set as “2”, then running speed is 1500 RPM, if pair of poles set as “1”, then running speed is 3000 RPM.

GU610A Controller Operation Manual

8.2 Generator Parameters:

NO.	Items		Preset	Value Range
2.1	Vac low alarm	8888	0	20-200% / 0 (not set)
2.2	Vac low pre-alarm	8888	90%	20-200% / 0 (not set)
2.3	Vac high pre-alarm	8888	115%	20-200% / 9999 (not set)
2.4	Vac high alarm	8888	9999	20-200% / 9999 (not set)
2.5	Hz low alarm	8888	45.0Hz	10.0-100.0Hz / 0 (not set)
2.6	Hz high alarm	8888	57.0Hz	10.0-100.0Hz / 999.9 (not set)
2.7	Over current pre-alarm	8888	100%	0-200%
2.8	Over current alarm	8888	150%	0-200%
2.9	Over current action	8888	0	0-1 (0- electrical tripping, 1-shutdown alarm)
2.10	Alarm delay	8888	10S	0-600 S
2.11	Gen. On delay	8888	5S	1-9999 S
2.12	GCB opening delay	8888	5S	1-9999 S

8.3 Engine Parameters:

NO.	Items		Preset	Value Range
3.1	Pair of poles	8888	2	1-4
3.2	Fuel mode	8888	0	0-1 / 0(NC) / 1 (NO)
3.3	T-sensor mode	8888	3	0-15 / 0 (not used)
3.4	P-sensor mode	8888	4	0-15 / 0 (not used)
3.5	Start delay	8888	10S	0-300 S
3.6	Crank attempt	8888	3 times	1-10 times
3.7	Crank time	8888	8S	0-30 S
3.8	Crank rest	8888	15S	0-300 S
3.9	Crank cutout RPM	8888	300RPM	1-9999 RPM
3.10	Idle delay	8888	0	0-9999 S
3.11	Preheat delay	8888	3S	0-300 S
3.12	Preheat mode	8888	1	1-3

GU610A Controller Operation Manual

3.13	Safety-on delay	8888	60S	0-600 S
3.14	Cool down delay	8888	300S	0-600 S
3.15	Stop delay	8888	20S	0-60 S
3.16	Under speed alarm	8888	0RPM	0-9999 RPM / 0 (not set)
3.17	Under speed Pre-alarm	8888	1440RPM	0-9999 RPM / 0 (not set)
3.18	Over speed Pre-alarm	8888	1600RPM	1-9999 RPM / 9999 (not set)
3.19	Over speed alarm	8888	1710RPM	1-9999 RPM / 9999 (not set)
3.20	low oil-press alarm	8888	1.4BAR	0-45.0 BAR
3.21	low oil-press pre-alarm	8888	2.2BAR	0-45.0 BAR
3.22	high temp pre-alarm	8888	95°C	70-320°C / 9999 (not set)
3.23	high temp alarm	8888	105°C	70-320°C / 9999 (not set)
3.24	low batt. pre-alarm	8888	8.0V	1.0-25.0V / 0 (not set)
3.25	high batt. pre-alarm	8888	28.0V	1.0-35.0V / 99.9 (not set)
3.26	charge V Pre-alarm	8888	8.0V	1.0-25.0V / 0 (not set)

8.4 Input and Output Setting:

NO.	Items		Preset	Value Range
4.1	Configurable input 1	8888	8	0-12 (define code as 8.7)
4.2	Configurable input 2	8888	7	0-12 (define code as 8.7)
4.3	Configurable input 3	8888	12	0-12 (define code as 8.7)
4.4	Input 1 delay	8888	2S	0-60 S
4.5	Input 2 delay	8888	2S	0-60 S
4.6	Input 3 delay	8888	2S	0-60 S
4.7	Configurable relay 1	8888	2	0-80 (define code as 8.8)
4.8	Configurable relay 2	8888	3	0-80 (define code as 8.8)
4.9	Configurable relay 3	8888	5	0-80 (define code as 8.8)

NOTE: configurable input delay is only for 1 to 4 codes in 8.7.

8.5 Calibration Menu:

NO.	Items		Preset	Value Range
5.1	Gen voltage V1	8888	0	±10.0%
5.2	Gen voltage V2	8888	0	±10.0%
5.3	Gen voltage V3	8888	0	±10.0%
5.4	Gen current I1	8888	0	±10.0%
5.5	Gen current I2	8888	0	±10.0%
5.6	Gen current I3	8888	0	±10.0%
5.7	Oil pressure	8888	0	±10.0%
5.8	Coolant temperature	8888	0	±10.0%
5.9	Battery voltage	8888	0	±10.0%

8.6 The optional items for P/T-sensor:

Code	The brand model of LOP sensor	The brand model of HET sensor
0	not used	not used
1	close for low oil pressure	close for high temperature
2	open for low oil pressure	open for high temperature
3	VDO 5 bar	VDO 120 °C
4	VDO 10 bar	VDO 150 °C
5	Datcon 7 bar	Datcon
6	Murphy 7 bar	Murphy
7	Pre-set 1	PT100
8	Pre-set 2	Pre-set 1
9	Pre-set 3	Pre-set 2
10	Pre-set 4	Pre-set 3
11	configured by user	Pre-set 4
12		configured by user



NOTE:

When the controller leaves factory, the optional types and functions of LOP sensor and HET sensor have been preset as the above table. If the using sensor is not listed in this table, the user can select “configurable”, and write sensor parameters to controller via software.

GU610A Controller Operation Manual

- LOP sensor parameter addendum:

VDO 5 bar:

P (Bar)	0.0	0.5	1.0	1.5	2.0	2.5	3.0	3.5	4.0	4.5	5
P (PSI)	0	7.3	14.5	21.8	29.0	36.3	43.5	50.8	58.0	65.3	72.5
R (Ω)	11	29	47	65	82	100	117	134	151	167	184

VDO 10 bar:

P (Bar)	0.0	1.0	2.0	3.0	4.0	5.0	6.0	7.0	8.0	9.0	10.0
P (PSI)	0	14.5	29.0	43.5	58.0	72.5	87.0	101.5	116.0	130.5	145.0
R (Ω)	10	31	52	71	90	106	124	140	155	170	184

Datcon 7 bar:

P (Bar)	0.0	0.7	1.4	2.1	2.8	3.4	4.1	4.8	5.5	6.2	6.9
P (PSI)	0	10.0	20.0	30.0	40.0	50.0	60.0	70.0	80.0	90.0	100.0
R (Ω)	240	200	165	135	115	95	78	63	48	35	25

Murphy 7 bar:

P (Bar)	0.0	0.7	1.4	2.1	2.8	3.4	4.1	4.8	5.5	6.2	6.9
P (PSI)	0	10.0	20.0	30.0	40.0	50.0	60.0	70.0	80.0	90.0	100.0
R (Ω)	240	205	171	143	123	103	88	74	60	47	33

Pre-set 1:

P (Bar)	0.0	1.0	2.0	3.0	4.0	5.0	6.0	7.0	8.0	9.0	10.0
P (PSI)	0	14.5	29.0	43.5	58.0	72.5	87.0	101.5	116.0	130.5	145.0
R (Ω)	15	31	49	66	85	101	117	132	149	164	178

Pre-set 2:

P (Bar)	0.0	1.0	2.0	3.0	4.0	5.0	6.0	7.0	8.0	9.0	10.0
P (PSI)	0	14.5	29.0	43.5	58.0	72.5	87.0	101.5	116.0	130.5	145.0
R (Ω)	30	41	65	88	110	115	145	150	172	185	190

GU610A Controller Operation Manual

Pre-set 3:

P (Bar)	0.0	1.7	3.4	5.2	6.9	8.6	10.3			
P (PSI)	0	25	50	75	100	125	150			
R (Ω)	21	36	52	72	84	100	120			

Pre-set 4:

P (Bar)	0.0	1.0	2.0	3.0	4.0	5.0	6.0	6.5	7.0	8.0	9.0
P (PSI)	0	14.5	29.0	43.5	58.0	72.5	87.0	94.3	101.5	116.0	130.5
R (Ω)	251	195	155	127	107	88	72	65	61	54	48

- HET sensor parameter addendum:

VDO 120°C:

T (°C)	40	50	60	70	80	90	100	110	120	130	140
T (°F)	104	122	140	158	176	194	212	230	248	266	284
R (Ω)	291	197	134	97	70	51	38	29	22	18	15

VDO 150°C:

T (°C)	50	60	70	80	90	100	110	120	130	140	150
T (°F)	122	140	158	176	194	212	230	248	266	284	302
R (Ω)	322	221	155	112	93	62	47	37	29	23	19

Datcon:

T (°C)	40	50	60	70	80	90	100	110	120	130	140
T (°F)	104	122	140	158	176	194	212	230	248	266	284
R (Ω)	900	600	400	278	200	141	104	74	50	27	4

Murphy:

T (°C)	40	50	60	70	80	90	100	110	120	130	140
T (°F)	104	122	140	158	176	194	212	230	248	266	284
R (Ω)	1029	680	460	321	227	164	120	89	74	52	40

GU610A Controller Operation Manual

PT100:

T(°C)	-100	-50	0	20	40	60	80	100	150	200	300
T(°F)	-148	-58	32	68	104	140	176	212	302	392	572
R(Ω)	60	81	100	108	116	123	131	139	157	176	212

Pre-set 1:

T(°C)	20	30	40	50	60	70	80	90	100	110	120
T(°F)	68	86	104	122	140	158	176	194	212	230	248
R(Ω)	900	600	420	282	152	113	86	62	48	40	30

Pre-set 2:

T(°C)			30	50	60	70	80	90	100	110	120
T(°F)			86	122	140	158	176	194	212	230	248
R(Ω)			980	400	265	180	125	90	65	50	38

Pre-set 3:

T(°C)	20	30	40	50	60	70	80	90	100	110	120
T(°F)	68	86	104	122	140	158	176	194	212	230	248
R(Ω)	805	540	380	260	175	118	83	58	42	30	21

Pre-set 4:

T(°C)	28	35	40	50	60	70	80	90	95	98	
T(°F)	82	95	104	122	140	158	176	194	203	208	
R(Ω)	579	404	342	250	179	136	103	77	67	63	

8.7 The optional items for configurable input:

Code	Optional Function	NOTE
0	not used	
1	Pre-alarm (active immediately)	low level is active
2	Shutdown Alarm (active immediately)	low level is active
3	Pre-alarm (active after safety-on delay)	low level is active
4	Shutdown Alarm (active after safety-on delay)	low level is active
5	LOP switch	low level is active
6	HET switch	low level is active
7	Emergency stop	low level is active
8	Remote start signal	low level is active
9	Reserved	low level is active
10	Gen Aux. Switch closed	low level is active
11	Low fuel level	low level is active
12	Lamp test	low level is active

8.8 The optional items for configurable output:

Code	Failure Type Define	Code	Failure Type Define
0	Not used	1	Over current tripping
2	Alarm	3	Pre-alarm
4	Idle 0 (N.C.)	5	Preheat
6	Speed up	7	Reserved
8	Fuel pump control	9	Running
10	System in AUTO mode	11	Reserved
12	System in MAN mode	13	Reserved
14	Idle 1 (N.O.)	15	Reserved
16	GCB failure (within 5s)	17	Fail to start



NOTE:

If define one configurable relay as **Speed up**, the relay will close after the engine has successfully started. If there is idle function, the relay will close after idle timer times out.

9. LCD Display and Menu System

Using a backlit TN type LCD to display data and information. After pressing any push button the backlight will automatically turn off in a preset time. In normal operating status, you can set the page scroll time to circularly display each page of measuring data. Press “▶” manually scrolls to view each measuring data. When failure occurs, LCD displays the corresponding failure icon.

Press and hold “▶” button 2sec to enter into parameters setting menu, then use “◀” or “▶” to scroll page, press “▶” again to select the required modify item, press “◀” or “▶”, LCD displays 0 0 0 when prompted to enter password, then use “◀” or “▶” to modify the first digital value, press “▶” move to modify the next one, after this, the first digital value will be displayed as “H”. Press “▶” to confirm after the password is set as 2213, then you can modify parameters. Otherwise it will prompt to key in password again. Press and hold “▶” for more than 2sec to quit parameters setting mode after finishing configuration.

9.1 Static LCD displays

Controller is in standby status, circularly displays each measuring data:

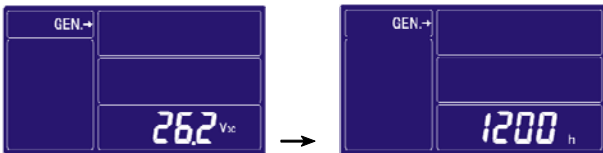

Controller is normally running, circularly displays each measuring data:

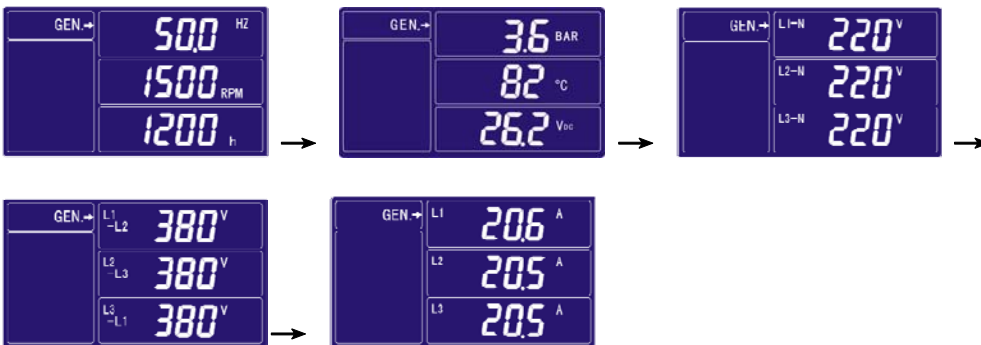

NOTE:

- When T-sensor or P-sensor is set as “not used”, LCD will not display related measuring data.

GU610A Controller Operation Manual

9.2 Setting running parameters





For example: (setting CT rate at 1000/5, then CT should be set at 200)

Operation	Description
Press and hold “▶” 2sec, to enter into parameter settings menu, then LCD displays:	
press “▶”, then LCD displays:	
Press “I”, prompted enter password, then LCD displays:	
Press “I” or “O” enter the password: (2213), then press “▶” again, press “I” or “O” to change parameter, change at 200, then LCD displays:	
Press “▶” to confirm, then press “O”, then LCD displays:	
Press “▶” again to quit, or press and hold “▶” more than 2s also can quit, then LCD displays:	













For example: (setting controller crank attempt at 2)

Operation	Description
Press and hold “▶” 2sec, enter into parameter settings menu, then LCD displays:	
Press “I” 28 times and then press “▶”, then LCD displays:	
press “I” prompted enter password, then LCD displays:	
Key in password: (2213), press “▶”, then LCD displays:	













GU610A Controller Operation Manual

<p>Press “    </p>

For example: (resume all parameters of controller to factory default)

Operation	Description
<p>Press and hold “   </p>	
<p>Press “  </p>	
<p>press “    </p>	
<p>Press “   </p>	

For example: (set controller as online program mode)

Operation	Description
<p>Press and hold “   </p>	
<p>Press “  </p>	
<p>press “    </p>	
<p>Press “    </p>	

10. Preparation before Starting the Controller

- 10.1 Make sure the controller is correctly installed to meet the ambient requirements.
- 10.2 Confirm all wiring connections of the controller meet the correct electric specification and corresponding to “2.3 typical wiring diagram”. Ensure the correct polarity of the DC supply source and that it has been protected by an external fuse. Otherwise damage to the controller may occur.
- 10.3 We recommend mounting an “Emergency Stop” button externally. The emergency stop input could be connected to N.O. contact of emergency stop push button, and the other contactor point be connected to the battery negative.
- 10.4 Switch on DC working power, make sure the preset parameters meet practical operating conditions, such as P-sensor mode, T-sensor mode, etc.

11. Technical Specification

DC working power

Voltage range: 12V/24V (8-35V continuous)

Cranking drop outs: 0V for 100mS, assuming dc supply was at least 10V before dropout and recovers to 5V

Max. operating current: @12V 180mA, @24V 90mA

Standby current: TBA

AC input voltage: phase voltage 15-300Vac RMS (AC frequency \geq 40 Hz)

AC input frequency: 3-70Hz (voltage \geq 15V)

Accuracy: 1%

Aux Control relay output: 3A/30Vdc

Start relay output: 3A/30Vdc

Fuel relay output: 3A/30Vdc

Protection: IP65 (when correctly installed)

Operating ambient temperature: -20 to 70°C

Storage ambient temperature: -30 to 80°C