

# GTR-117

## Generator Controller

### Manual



Web Site : <http://www.monicon.com.tw>







E-mail : [sales@monicon.com.tw](mailto:sales@monicon.com.tw)

# 1. Controller Description

GTR-117 is a multi-function diesel engine generator controller. It applies with 3 buttons and provides 3 kinds of operation mode: Manual, Auto, Off. No special training is required due to the easy operation. Fault protection includes: Emergency stop, Over speed, High water temperature, Low oil pressure, Low frequency, Aux. input 1 and Over crank. GTR-117 also displays the low battery voltage warning, and indicates the running status, speed status and power status. GTR-117 equips with high firm continental-type terminal that provides easy plug in and removal. Furthermore, GTR-117 has 10 pins Dip switch for adjusting parameter according to system requirements, and make it not only reducing stock but also meeting the various system specifications. GTR-117 build-in 5 output powers relays which perform high power capacity reach to 5 Amp (DC) that saves the wiring for connection with extra power relays. No matter in function, protection or operation performance. GTR-117 is your best choice.

## 2. Profile

### A、LCD Icon Descriptions

Icon	Descriptions	Icon	Descriptions
	Emergency Stop	<b>LOWBATT</b>	Low Battery Volt
	High Water Temp.	<b>DC</b>	DC System
	Low Oil Pressure	<b>V</b>	Volt Unit
	Crank Failure	<b>Hr</b>	Run Hour
	Over Speed	<b>Hz</b>	Frequency Unit
	Run		Low Frequency
<b>AUTO</b>	Auto Mode	<b>!1</b>	Aux. Input 1
<b>OFF</b>	Off	<b>RPM</b>	RPM Value
<b>MAN.</b>	Manual Mode		

### B、Operation Button Switch

- **ATS**  
Auto Start function by detect ATS terminal 12 grounded.
- **Off**  
Stop running engine or stand still / Reset Alarm.
- **Manual**  
Manual start engine directly.

### 3. Back Panel Function Description

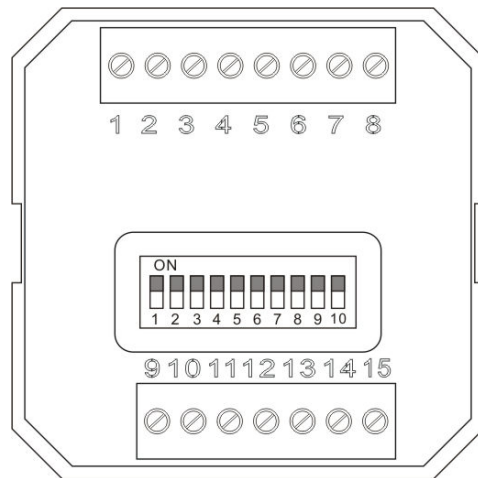

Fig. 2 GTR-117 Controller Back Panel

E u r o p i u m S t y l e C o n n e c t o r	Number	Description	Code
	1	Input power (Battery +)	++
	2	Ground (Battery -)	GND
	3	Output starter relay	Motor
	4	Output fuel valve relay	Valve
	5	Output alarm relay	Alarm
	6	Output stop relay	Stop
	7	Idle/Pre-heat relay	PreHeat
	8	Charge fire point	Charge
	9	Aux. Input 1 switch	Aux. 1
	10	Aux. switch shutdown	Em.Stop
	11	Input , High water temp.	H.W.T.
	12	Input, Low oil press.	L.O.P.
	13	Input , Auto start	ATS
	14	Input , Frequency detect terminal	F.D.1
15	Input , Frequency detect terminal	F.D.2	

## A 、 Dip switch settings function

- Pin 1 & Pin 2 : Valve on to stop engine timer

Pin1	Pin2	Valve on stop engine delay
OFF	OFF	5 sec
ON	OFF	10 sec
OFF	ON	15 sec
ON	ON	20 sec

List 2 Stop Period

- Pin3 : System frequency 【ON : 50Hz ; OFF : 60Hz】
- Pin4 : Escape motor by oil pressure switch 【ON : Enable ; OFF : Disable】
- Pin5 : Pressure switch type 【ON : Normal Open ; OFF : Normal Close】
- Pin6 : Idle / Pre-heat output delay time 【ON : 10 ( 120 ) Sec ; OFF : 1 ( 10 ) Sec】
- Pin7 : Low DC Volt 【ON : 10.5VDC ; OFF : 21VDC】
- Pin8 & Pin9 Cooling time :

Pin8	Pin9	Cooling time
OFF	OFF	0 Sec
ON	OFF	60 Sec
OFF	ON	150 Sec
ON	ON	300 Sec

List 3 Cooling Time

- Pin10 : Idle / Pre-heat Function Select 【ON : Idle ; OFF : Pre-heat】

## 4. Case Dimension

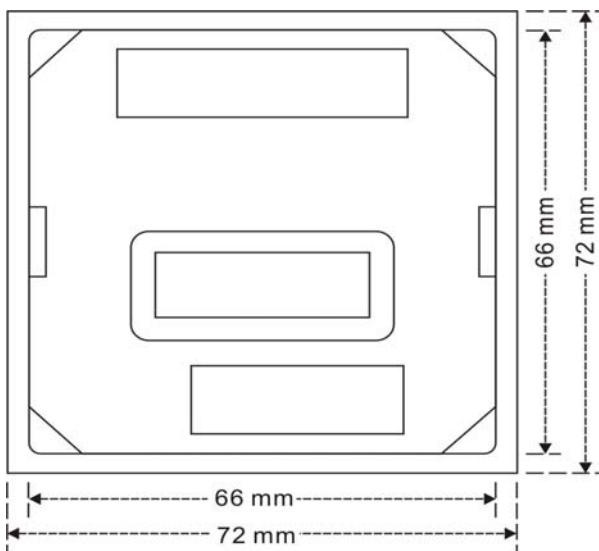

Fig. 3 GTR-17 Case Dimension of Back View

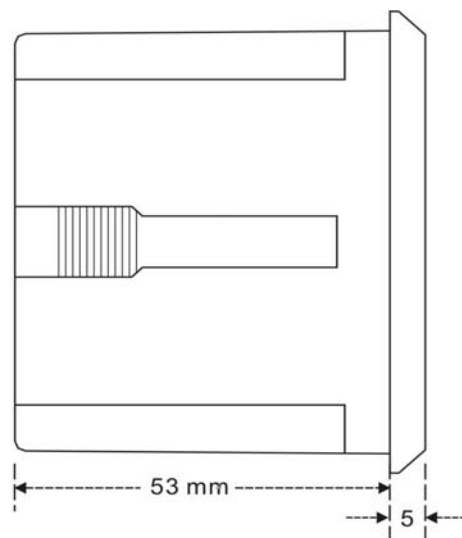

Fig. 4 GTR-17 Case Dimension of Back View

## 5. Specifications

**DC supply :**

8~36 VDC

**Power Consumption :**

Max.5 W

**Measuring Frequency :**

0~75 Hz (min AC Volt. 5 V ; max AC Volt. 300V)

**Relay Output :**

Start output : 5A

Valve output : 5A

Idle / Pre-heat output : 5A

Alarm Output : 5A

Stop output : 5A

**Ambient Temperature Range :**

-30 °C ~ 70 °C

**Dimension (W \* H \* D) :**

72mm x 72 mm x 58 mm

**Panel cut-out (W \* H) :**

68 mm x 68 mm

**Weight :**

190 g (0.42 lb.)

### Protections and parameters :

Auxiliary shutdown protection: 1 Sec., Normal Close

Low battery warning: 5 Sec., 10.5 / 21 VDC

Over speed protection: 2 Sec., 55/66 Hz

Low Frequency Protection : 6 Sec., Stop

Aux. Input 1 : 3 Sec., Stop

High water temp. protection: 2 Sec., Normal Open

Low oil pressure protection: 2 Sec., Normal Open / Normal Close

Over crank: 3 attempts

Cranking speed up limited: 0.5 Sec., 16Hz

Safety on timer: 5 Sec (\*)

(\*) All alarms are ignored until safety on timer expired, except the emergency stop and over speed.

## 6. Controller Wiring Example

